



IAS2020, Jan. 20-24, 2020 at Hong Kong

CEPC injection and extraction design and hardware R&D plan

Jinhui Chen, X.H. Cui, D. Wang, Yiwei Wang, Lei Wang, Yuwen Wu, Hua Shi

Injection group

2020-1-20

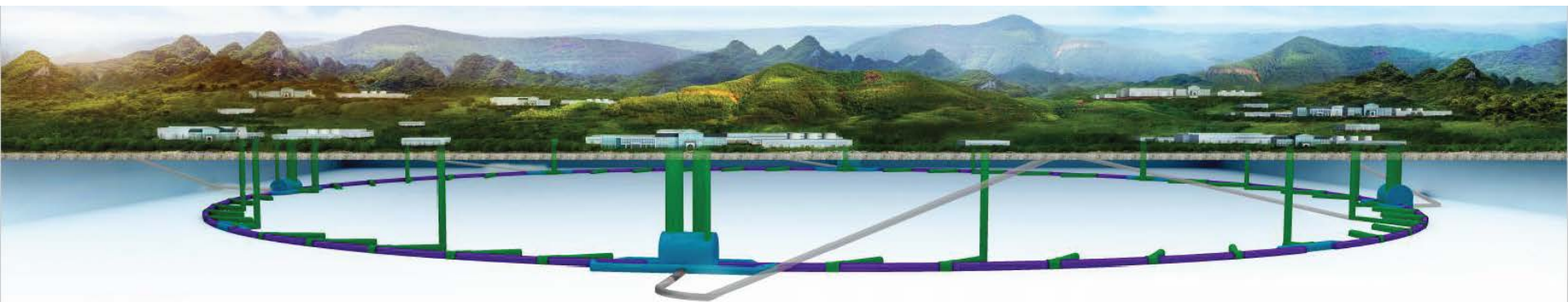

Circular Electron-Positron Collider



Outline

1 Overview of CEPC Inj./Ext. systems

2 Inj./Ext. systems layout preliminary design

3 Hardware design considerations

4 Summary

Overview of the CEPC injection and extraction systems



Layout of the accelerator complex

The CEPC accelerator complex consists of a **Linac**, which including a small **damping ring** for positron beams, several **transport lines**, a **booster ring** and 2 **storage rings**, all 3 of which are in a single tunnel.

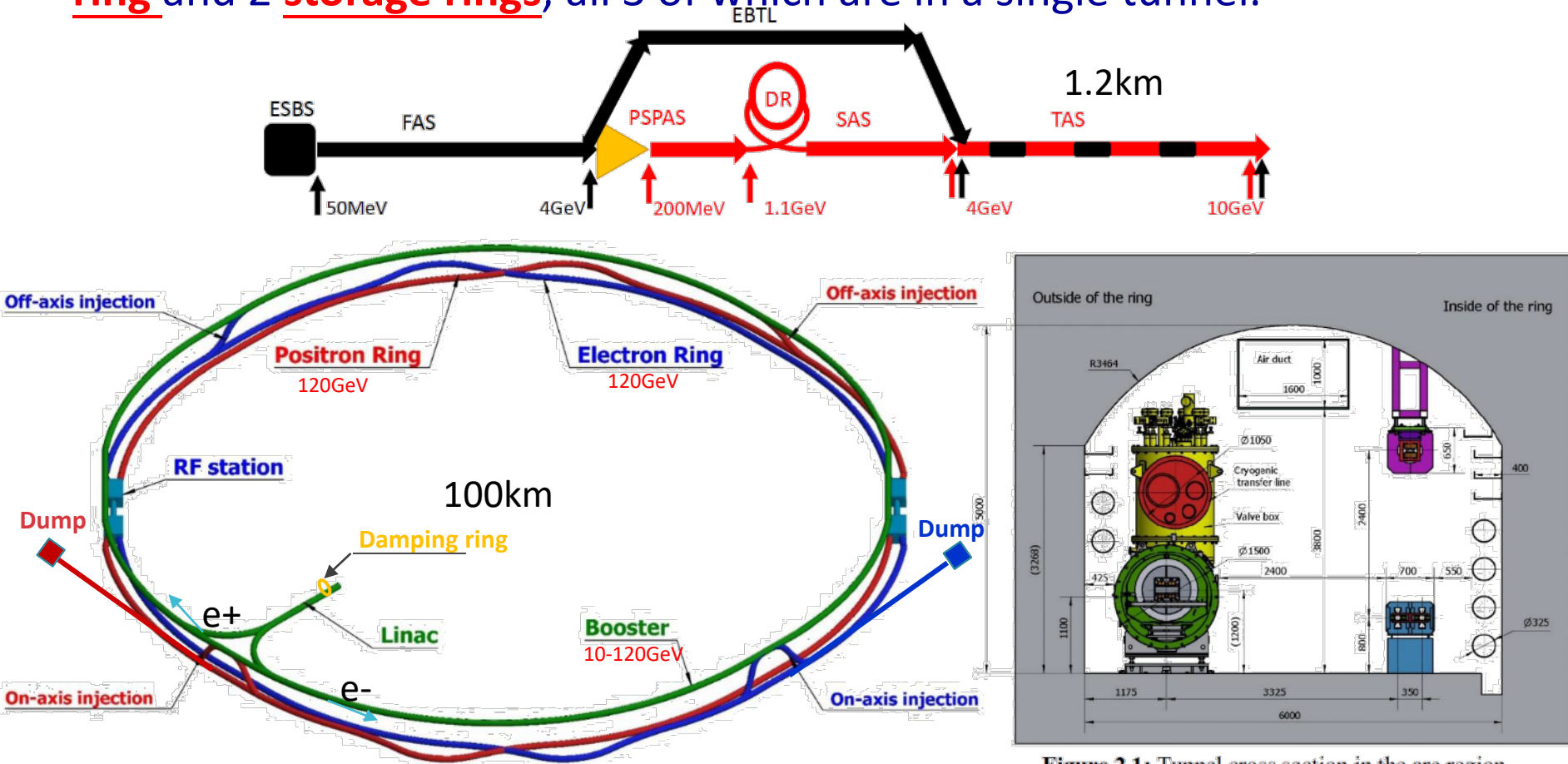

Figure 2.1: Tunnel cross section in the arc region



CEPC injection and extraction systems

There are 9 injection and extraction sub-systems in CEPC accelerator complex, including:

- ① DR injection and Extraction system(e+)
 - ② Booster LE injection system (e+,e-)
 - ③ Booster Extraction system1 (e+,e-)
 - ④ Collider off-axis injection system (e+,e-)
 - ⑤ Booster Extraction system2 (e+,e-)
 - ⑥ Booster HE injection system (e+,e-)
 - ⑦ Collider swap out injection system (e+,e-)
 - ⑧ Collider swap out extraction system (e+,e-)
 - ⑨ Collider beam dump system(e+,e-)
- Off-axis injection
(in W and Z mode)
- On-axis injection
(only in Higgs mode)

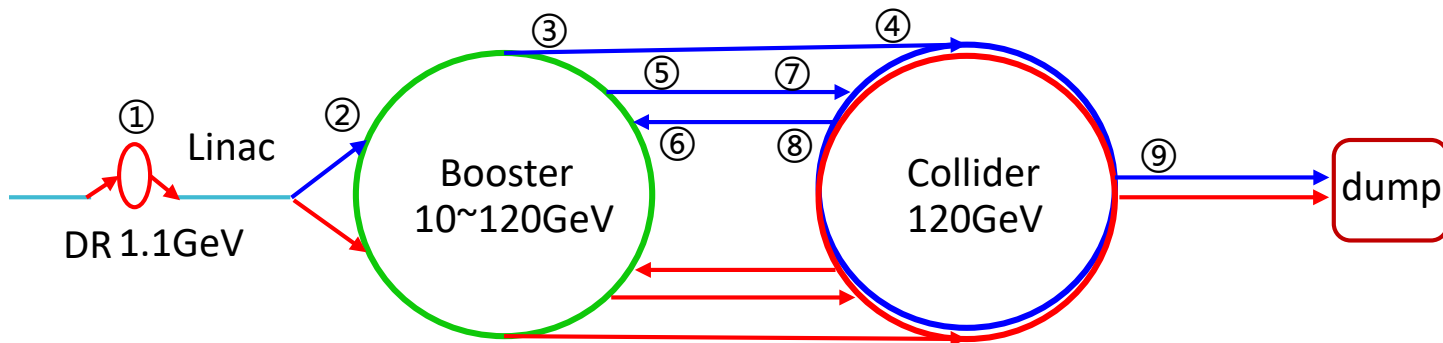



Injection Schemes Considerations

Top-up injection schemes for low emittance rings:

- Off-axis injection (need larger DA)---accumulating injection
 - Pulsed local bump injection
 - Pulsed septum field injection
 - multi-pole magnet injection
 - Nonlinear kicker injection
- On-axis injection (need smaller DA)
 - Transverse swap-out injection
 - Longitudinal accumulating injection

For the CEPC, from the Linac to the damping ring then to the booster and the collider rings, the beams are injected and extracted all by on-axis scheme.

In the collider rings, the both off-axis accumulating injection schemes are applicable for W and Z mode due to larger DA. On-axis swap-out injection scheme is the baseline one for Higgs mode for smaller DA. In this mode, the beams are accumulated by off-axis injection in the booster ring.

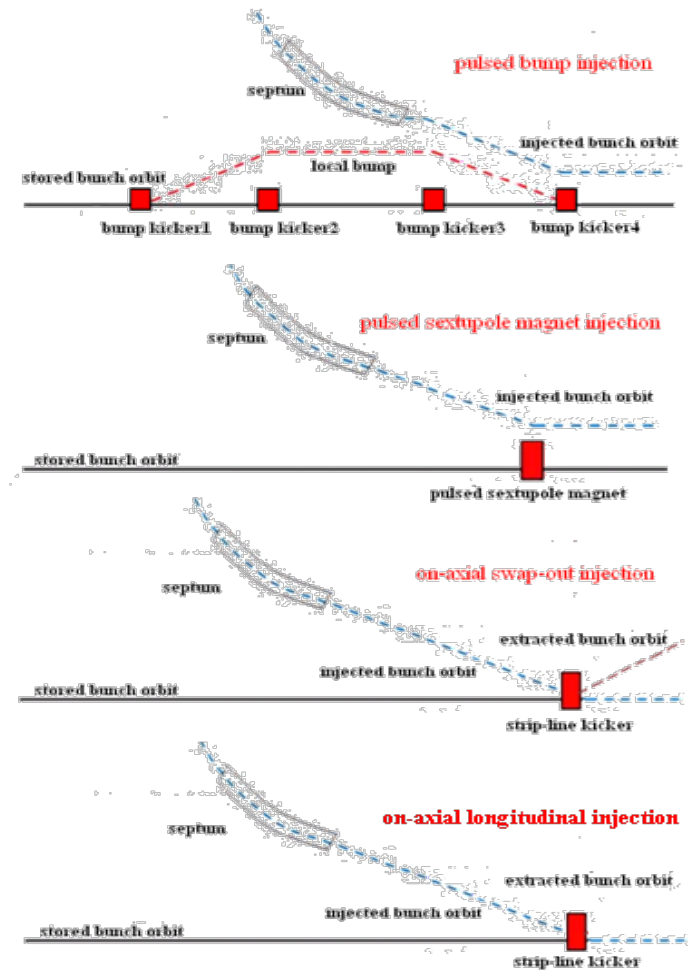

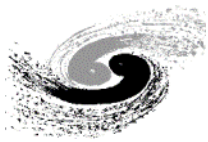

Injection components design considerations

- Injection and extraction components: Kicker and septa
- Lambertson magnet is the first choice for the septa, since there is height difference between the machines. Lambertson is more reliable than other types of septa with typical septum width from 2mm to 10mm.
- Which type of Kicker to choose is usually determined by the injection scheme, the waveform of pulse and required kick strength.
- The waveform of kicker pulse is determined by injection scheme, filling pattern and revolution period.
- The width of septum, kick strength and length of injection straight section should be considered together.
- A reasonable injection and extraction region layout design is very important for hardware design. This part is not available in CEPC CDR.
- In the past 3 months, the preliminary injection layout design was done. So far, we just figured out what kind type of the components needed in all subsystems. And we just proposed a hardware R&D plan in the coming years.

CEPC injection and extraction systems layout preliminary design



Damping Ring injection and extraction

- On-axis bunch-by-bunch injection
- Injection and extraction systems are totally occupied 2 long straight sections.

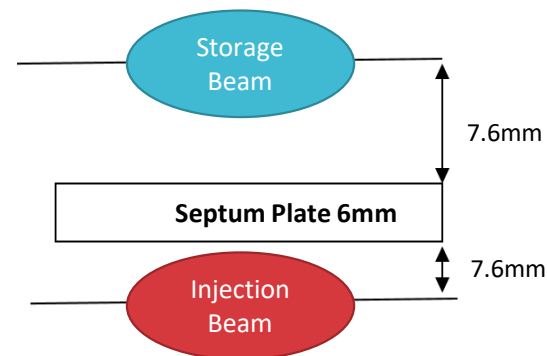
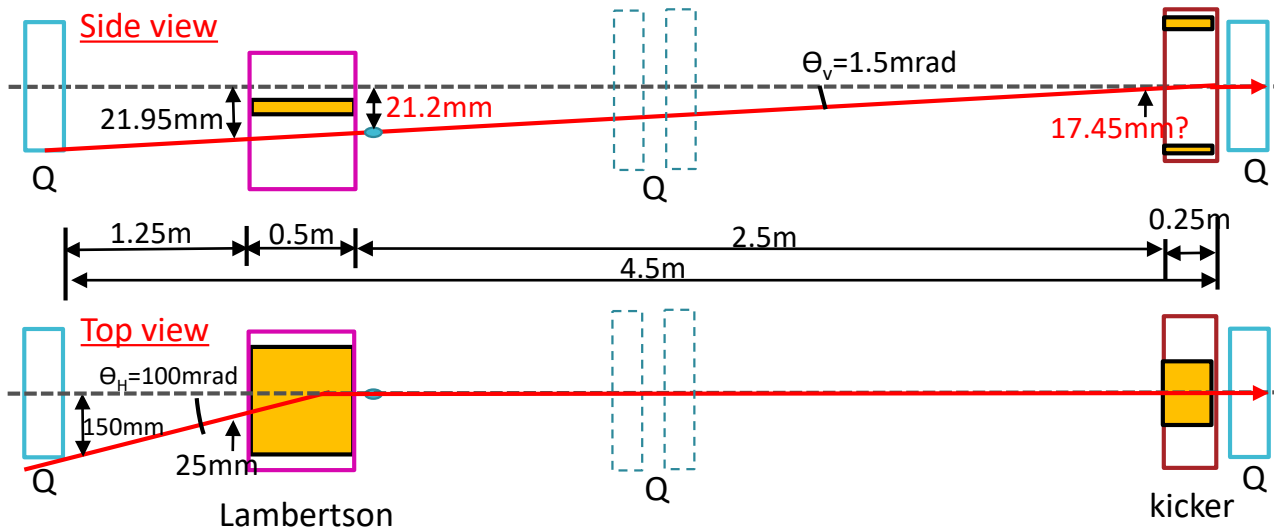
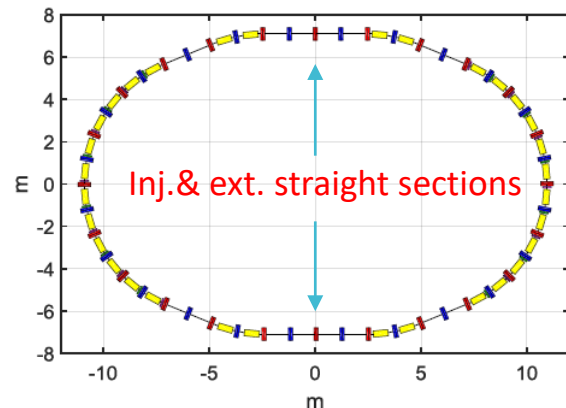
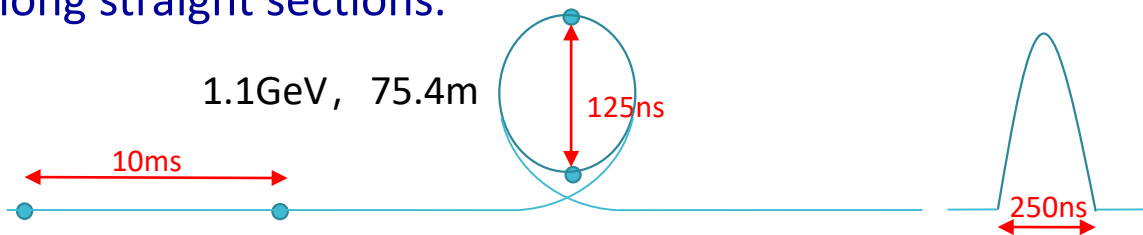

- **Lambertson:** length=0.5m, deflection angle=100mrad, B=0.72T
thickness of septum sheet=6mm Leakage field=$\lt; 5E-4(0.8\text{mm})$ Beam-Stay-clear(HxV)=25x15mm
- **Fast kicker:** pulse width<250ns, repetition rate=100Hz, length=0.25m, deflection angle=1.5mrad, B=0.02T, Beam-Stay-clear(HxV)=32x18.8mm (slotted pipe kicker)



Parameters of Hardware of DR

Kicker: Slotted pipe kicker

Septa: horizontal Lambertson magnet

	Injection	extraction
Energy (GeV)	1.1	1.1
Bunch number	2	2
Bunch spacing (ns)	125	125
Injection (extraction) mode	Bunch by bunch	Bunch by bunch
Kicker repetition rate (Hz)	100	100
Kicker pulse width (ns)	<250	<250
Kicker rise (fall) time (ns)	<125	<125
Timing delay(ns)	<125	<125
Kick angle (mrad)	1.5	1.5
Kicker Integral magnetic field strength (Tm)	0.006	0.006
Length of kicker (m)	0.25	0.25
Kick strength (T)	0.024	0.024
Kicker Beam-Stay-clear(HxV) (mm)	32x18.8	32x18.8
Kicker good field region (HxV) (mm)	38x22?	38x22?
Kicker field uniformity (%)	1	1
Septa deflection angle (mrad)	100	100
Septa Integral magnetic field strength (Tm)	0.36	0.36
Septa board thickness (mm)	6	6
Septa Circulating Beam-Stay-clear(HxV) (mm)		
Septa Injected beam-stay-clear (HXV) (mm)		
Septa good field region (HxV) (mm)		
septa field uniformity (%)		



Booster LE injection

On-axis bunch-by-bunch injection

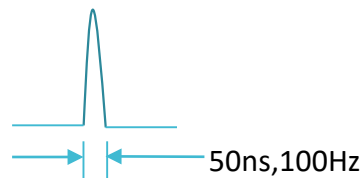
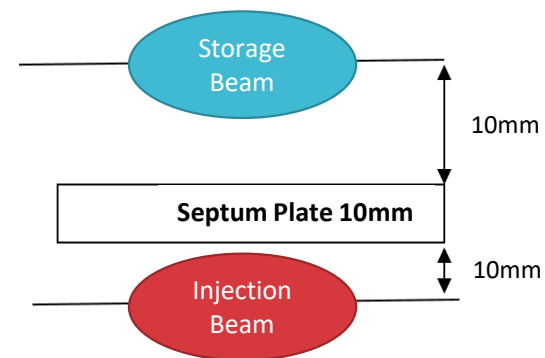
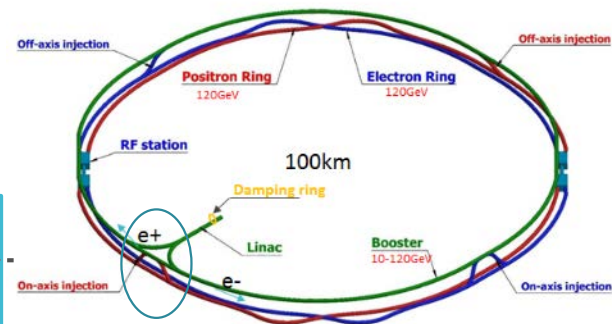
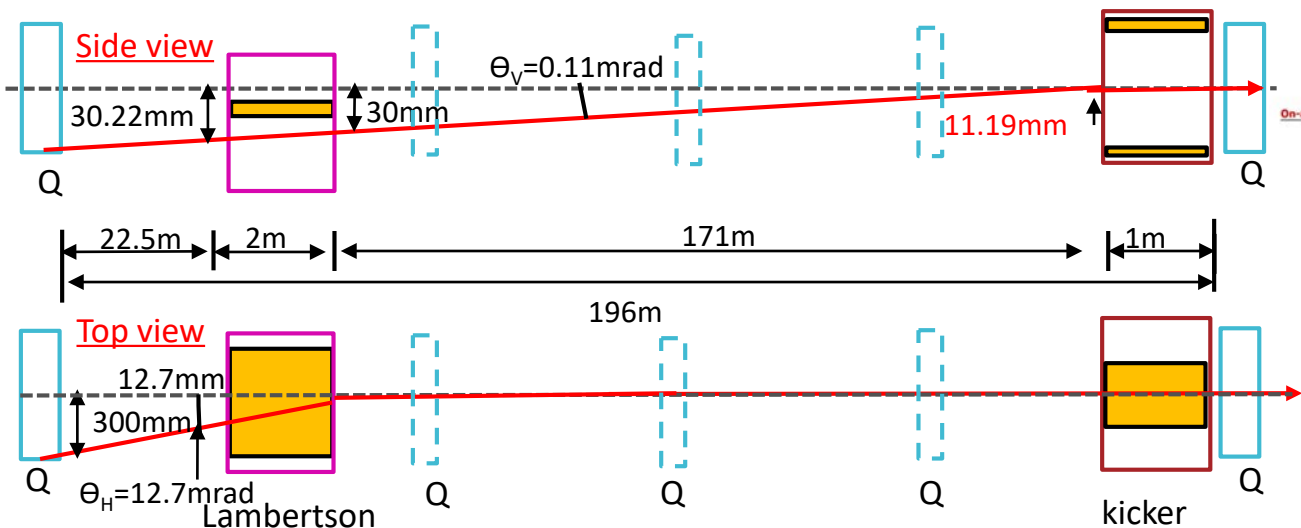

Kicker: vertical strip-line kicker driven by DSRD pulser

Septa: horizontal Lambertson magnet



Booster HE extraction for CR off-axis injection

- Train by train or bunch-by-bunch extraction

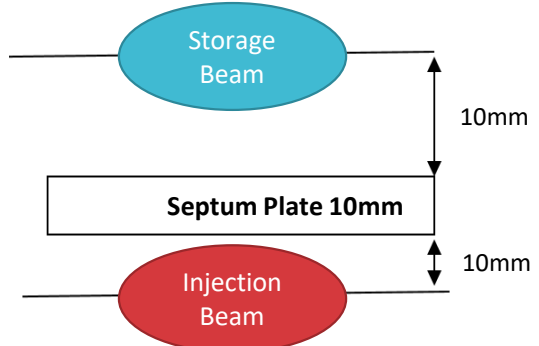
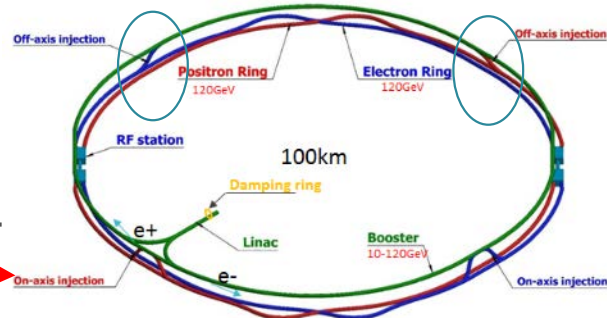
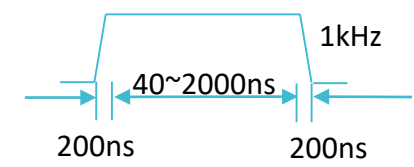
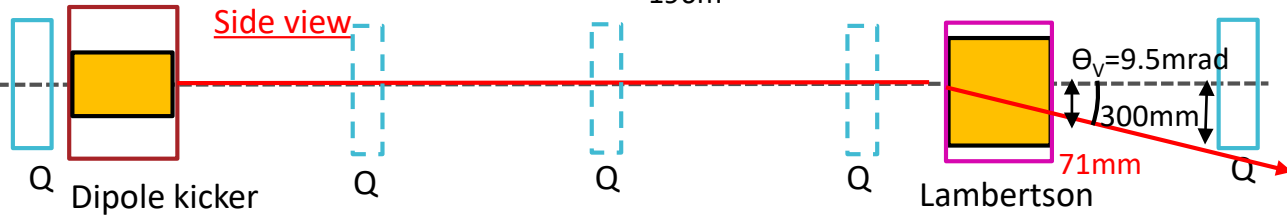
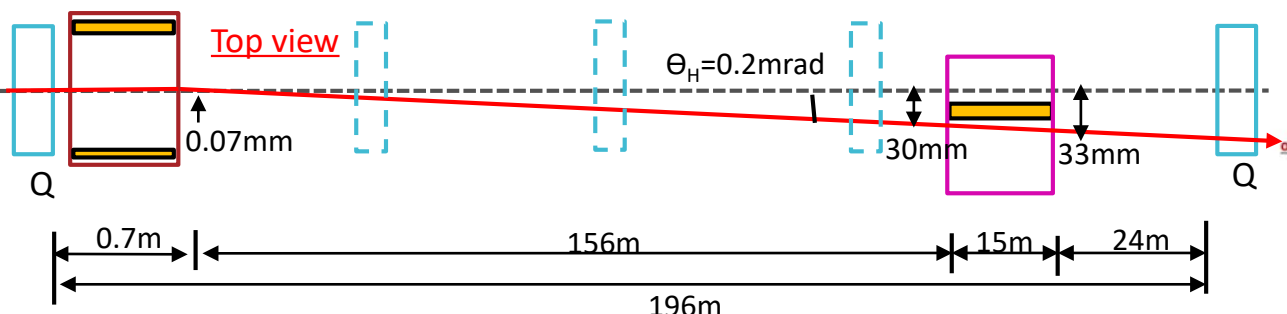

Kicker: horizontal out-vacuum delay-line dipole kicker (coating ceramic vacuum chamber) driven by PFN-based solid-state pulser

Septum: vertical Lambertson magnet



Collider ring off-axis injection

Top view

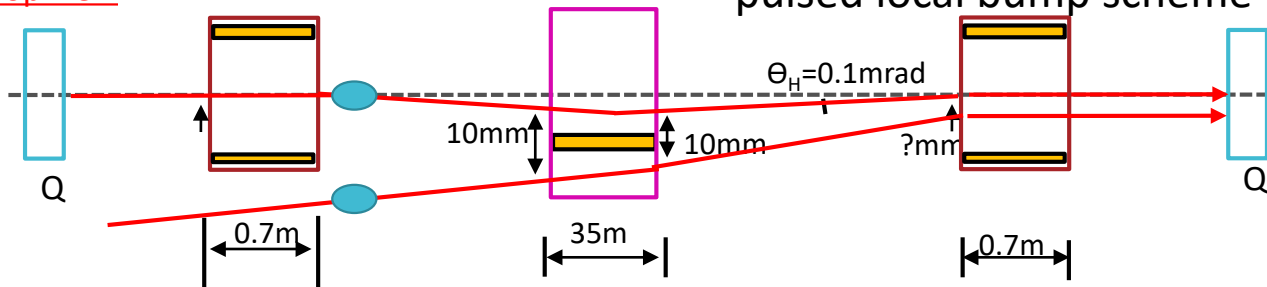

Side view

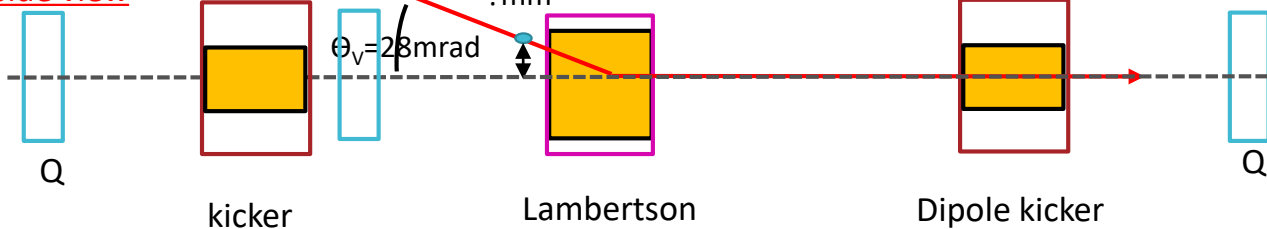

pulsed local bump scheme

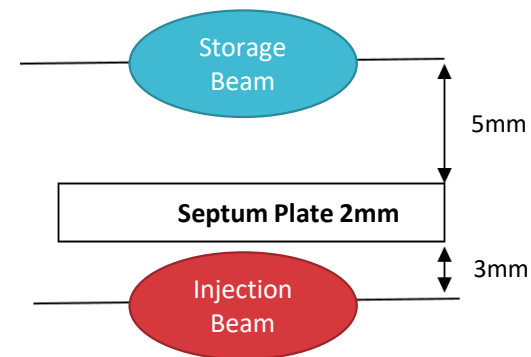

1. **Dipole kicker:** horizontal out-vacuum delay-line kicker+coating ceramic chamber+PFN-based solid-state pulser
2. **NLK kicker:** horizontal out-vacuum delay-line **NLK** kicker+coating ceramic chamber+PFN-based solid-state pulser
3. **Septa:** Vertical Lambertson magnet

pulsed multipole injection scheme

Top view

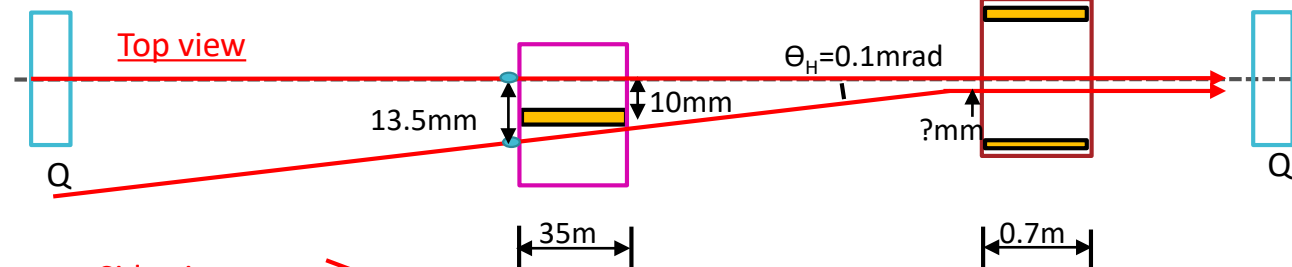

Side view

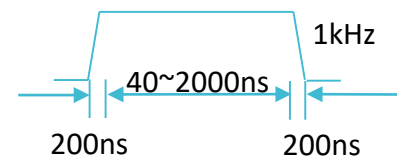
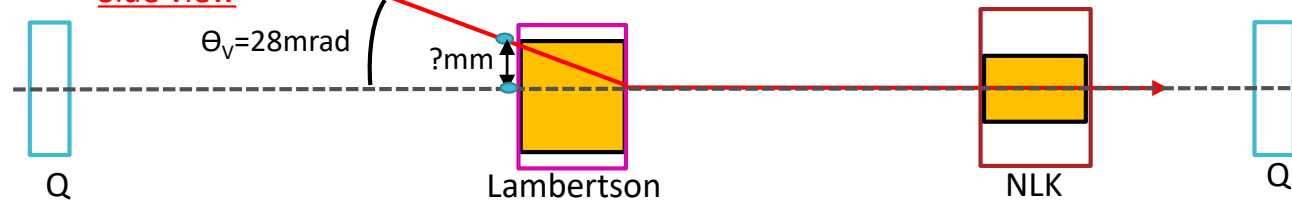



On-axis swap-out injection layout

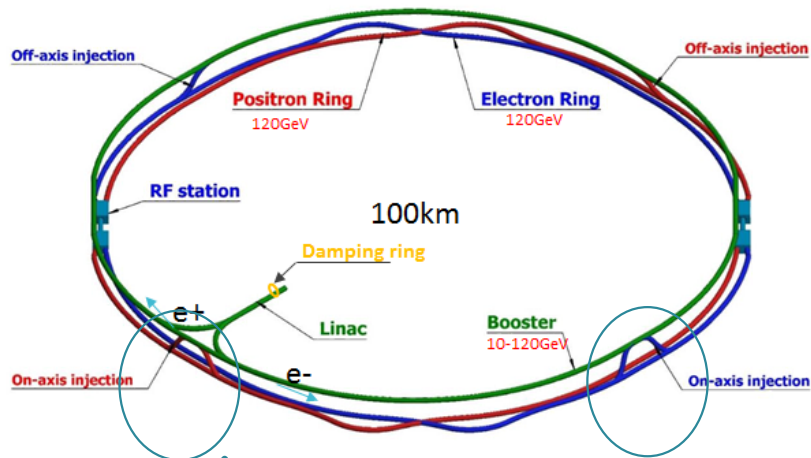

- Off-axis injection is used in the process of the booster high-energy re-injection. Both pulsed multipole injection and pulsed bump injection are suit.
- On-axis swap out injection is applied in CR. A set of dipole kicker can serve both injection and extraction process.

1. **Dipole kicker:** horizontal ferrite core out-vacuum kicker+coating ceramic chamber+LC resonance pulser
2. **Inj. NLK:** horizontal NLK or Pulsed sextupole+coating ceramic chamber+LC resonance pulser
3. **Septum:** Vertical Lambertson magnet

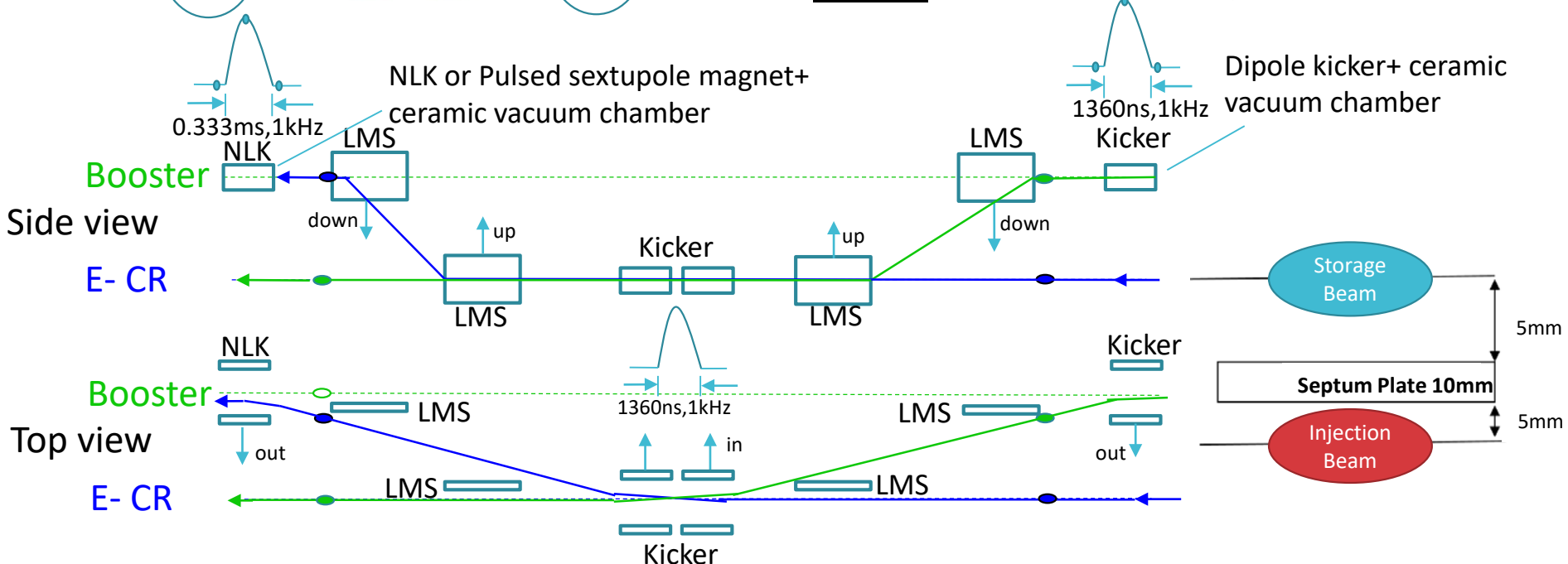



Dump extraction

- Train by train or bunch-by-bunch extraction

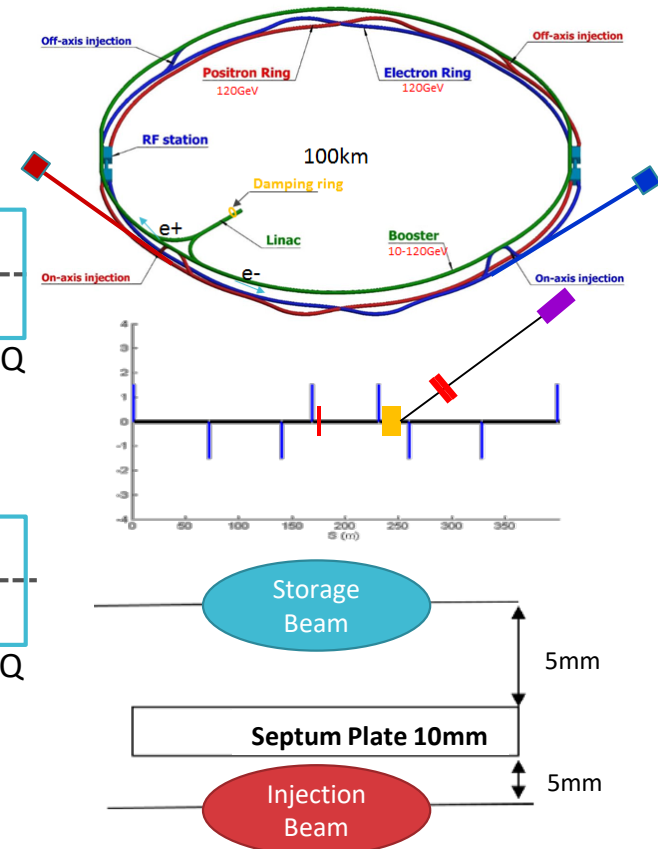
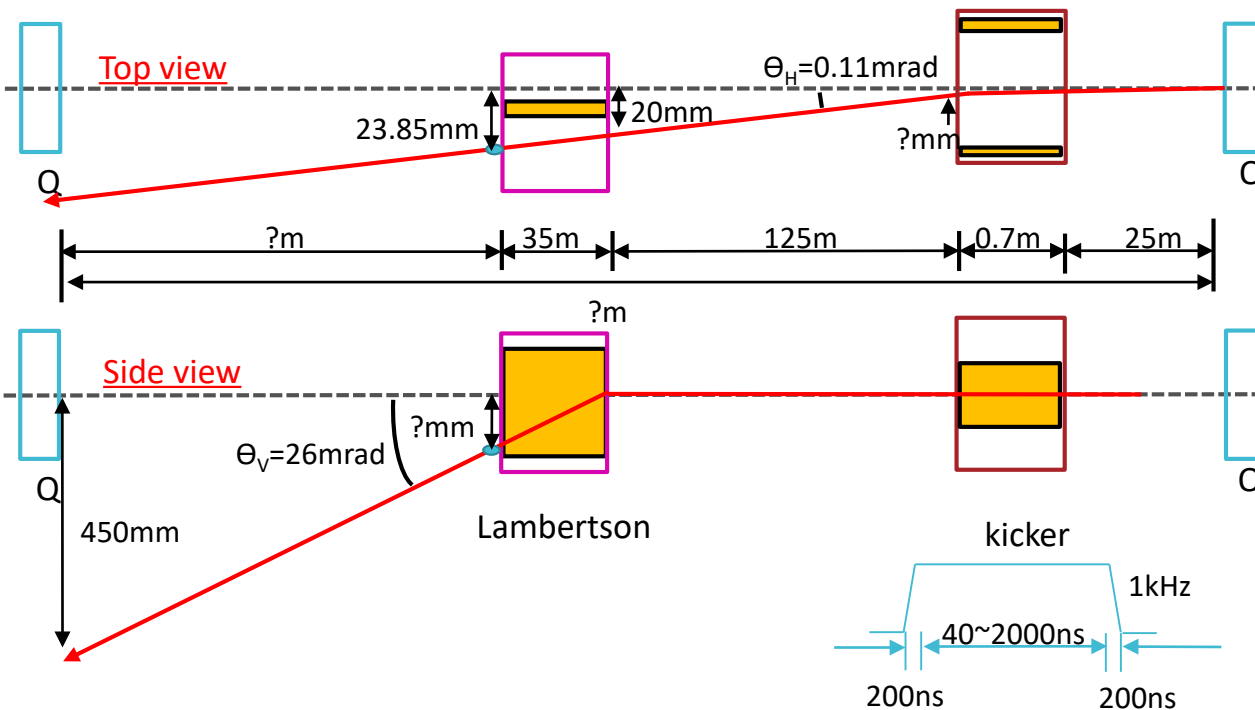

1. **Dipole kicker:** horizontal out-vacuum delay-line kicker+coating ceramic chamber+PFN-based solid-state pulser
2. **Septa:** Vertical Lambertson magnet



Booster Ring

Booster operating mode	Higgs			W		Z	
Beam energy (GeV)	10	120		10	80	10	45.5
Function	Injection (both)	Extraction (off-axis)	Inj./Ext. (on-axis)	Injection (off-axis)	Extraction (off-axis)	Injection (off-axis)	Extraction (off-axis)
Bunch number	242 (in half ring)		7 (in half ring)	1524 (uniform)		6000	
Min. bunch spacing (ns)	680		23800	220		25	
Bunch number per train × train number	-		-	-		80 × 75	
Train spacing (ns)	-		-	-		2460	
Injection (extraction) mode	Bunch by bunch			Bunch by bunch		Bunch by bunch	Train by train
Kicker repetition rate (Hz)	100	1000		100	1000	100	1000
Kicker pulse width (ns)	1360			440		50	<6900
Kicker flat top (ns)	-			-		-	>1980
Kicker rise (fall) time (ns)	<680			<220		<25	<2460
Timing delay (ns)	<680		<23800	<220		<2460	<4400
injection (extraction) period (s)	2.42	0.242	0.007	15.24	1.5	60	0.075
Kick angle (mrad)	0.11	0.2	0.1	0.11	0.2	0.11	0.2
Kick Integral field strength (Tm)	0.004	0.08	0.04	0.004	0.05	0.004	0.03
Beam pipe aperture Φ (mm)	55						

Considering the compatibility of three operating modes:

Function	LE-Injection (both)	HE-Extraction (off-axis)	HE-Inj./Ext. (on-axis)
Kicker repetition rate (Hz)	100	1000	1000
Kicker pulse width (ns)	50	440~2420(Adjustable)	1360
Kicker flat top (ns)	-	0~1980(Adjustable)	-
Kicker rise (fall) time(ns)	<25	<220	<680
injection (extraction) period (s)	60	1.5	0.007
Kick angle (mrad)	0.11	0.2	0.1
Kick Integral field strength (Tm)	0.004	0.08	0.04
Beam pipe aperture Φ (mm)	55	55	55

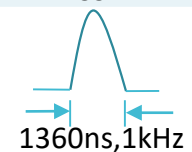
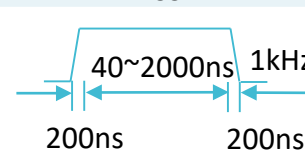



Collider ring

Booster operating mode	Higgs			W		Z	
Beam energy (GeV)	120			80		45.5	
Function	Injection (off-axis)	Injection (on-axis)	Extraction (dump)	Injection (off-axis)	Extraction (dump)	Injection (off-axis)	Extraction (dump)
Bunch number	242 (in half ring) - 7			1524 (uniform)		12000	
Min. bunch spacing (ns)	680			220		25	
Bunch number per train × train number	-			-		80 × 150	
Train spacing (ns)	-			-		245	
Injection (extraction) mode	Bunch by bunch			Bunch by bunch		Train by train	
Kicker repetition rate (Hz)	1000			1000		1000	
Kicker pulse width (ns)	1360			440		<2460	
Kicker flat top (ns)	-			-		>1980	
Kicker rise (fall) time (ns)	<680			<220		<245	
Timing delay(ns)	<680	<23800	<680	<220		<4400	
injection (extraction) period (s)	0.242	0.007	0.242	1.5		0.15	
Kick angle (mrad)	0.1	0.2	0.2	0.1	0.2	0.1	0.2
Kick Integral field strength (Tm)	0.04	0.08	0.08	0.027	0.05	0.015	0.03
Beam pipe aperture HxV (mm)	75 × 56						

Considering the compatibility of three operating modes:

Function	Injection (on-axis)	Injection (off-axis)	Extraction (dump)
Kicker repetition rate (Hz)	1000	1000	1000
Kicker pulse width (ns)	1360	440~2420(Adjustable)	440~2420(Adjustable)
Kicker flat top (ns)	-	0~1980(Adjustable)	0~1980(Adjustable)
Kicker rise (fall) time(ns)	<680	<220	<220
injection (extraction) period (s)	0.007	1.5	1.5
Kick angle (mrad)	0.2	0.1	0.2
Kick Integral field strength (Tm)	0.08	0.04	0.08
Beam pipe aperture HxV (mm)	75 × 56	75 × 56	75 × 56

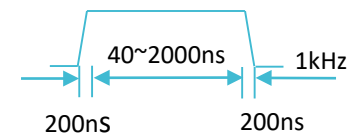
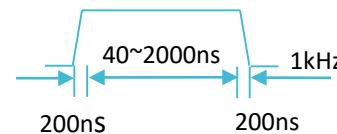
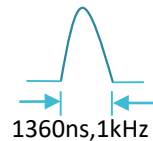



Alternative scheme of RF region beam separating system

- In Higgs mode, e^-/e^+ beams only fill half ring respectively. So, it is possible to separate beams by kickers.
- Compared with electrostatic separator, kicker magnet is stronger and contributes lower beam impedance.
- 4 sets of kicker locate at both sides of RF region, K1 and k4 applied for e^+ beam, K2 and K3 for e^- beam;
- The waveform of kicker pulsers is square wave with duty cycle of 50%, pulse width of 165 us and frequency of 6.06 kHz;
- The phase difference between K1 (K3) and K2(K4) is π .

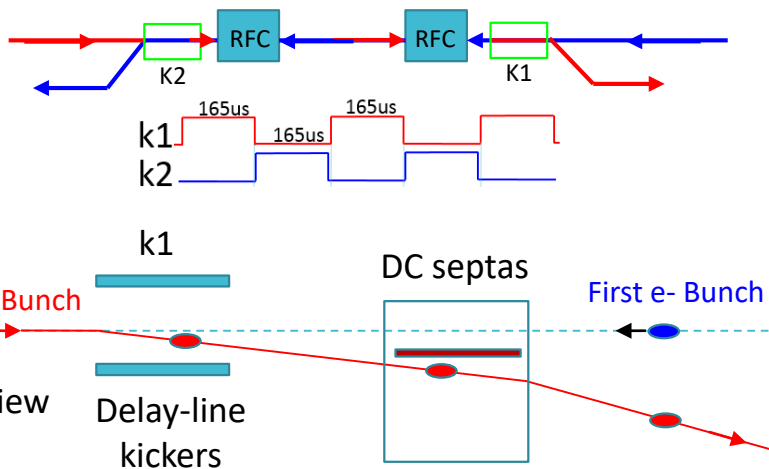
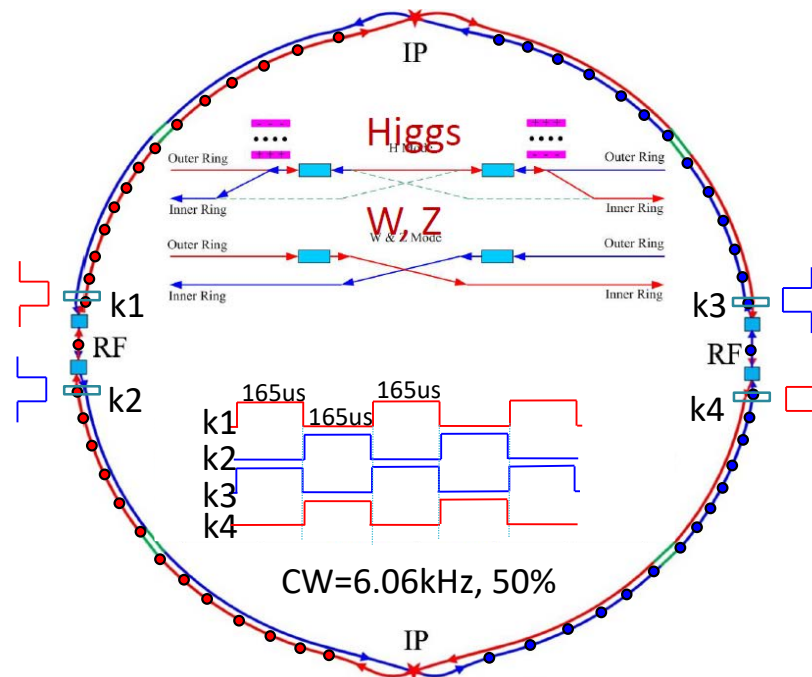

Yiwei Wang

	Kicker	Septa
Intergrated strength BL [T*m]	0.1624	1.4
Strength B [Guass]	203	1000
Effective length L_{eff} [m]	8	14
Half width of good field region	10.1/3.8	18.9/3.8
Hgf/Vgf [mm]	@ 5E-4	@ 5E-4
Half width of beam stay clear		
Hbsc/Vbsc [mm]	9.6/3.6	9.2/3.6
Septum width width [mm]	-	10

Hardware design consideration for CEPC injection and extraction systems



Main types of hardware

	Sub-system	Kicker Type	Kicker waveform	Septa Type
1	Damping ring inj./ext.	Slotted-pipe kicker	Half-sine/250ns	Horizontal LMS
2	Booster LE inj.	Strip-line kicker	Half-sine/50ns	Horizontal LMS
3	Booster ext. for CR off-axis inj.	Delay-line dipole kicker	Trapezoid /440-2420ns	Vertical LMS
4	Collider off-axis inj.	Delay-line NLK kicker	Trapezoid /440-2420ns	Vertical LMS
5	Booster ext. for CR on-axis inj.	Ferrite core dipole kicker	Half-sine/1360ns	Vertical LMS
6	Booster HE inj.	NLK or Pulsed sextupole	Half-sine/0.333ms	Vertical LMS
7	Collider swap out inj.	Ferrite core dipole kicker	Half-sine/1360ns	Vertical LMS
8	Collider swap out ext.	Ferrite core dipole kicker	Half-sine/1360ns	Vertical LMS
9	Collider beam dump	Delay-line dipole kicker	Trapezoid /440-2420ns	Vertical LMS
10	RF region beam separating	Delay-line dipole kicker	CW square / 165us,50%	Horizontal Copper septa

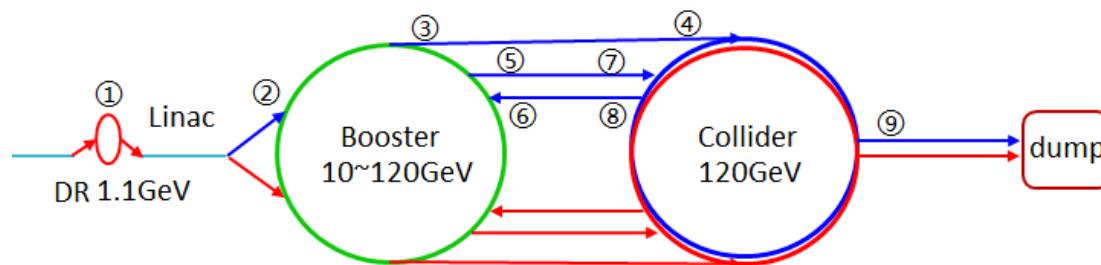

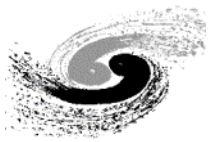

Lambertson septa design

- The similar hardware was developed in HEPS, CSNS, BEPC
- Higher reliability and stability
- The width of septum wall might be in the range from 2mm to 20mm.

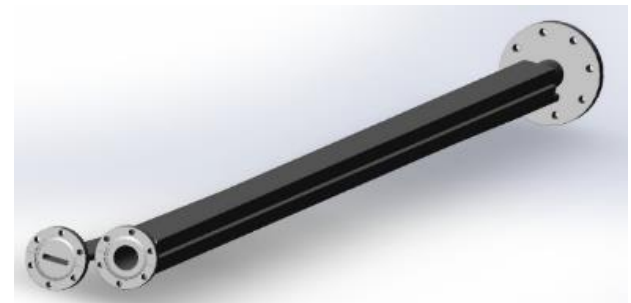
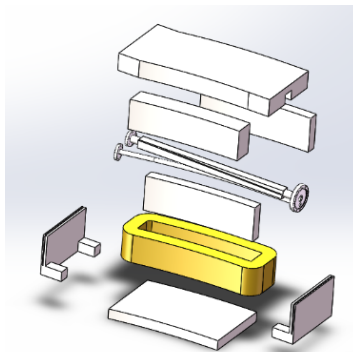
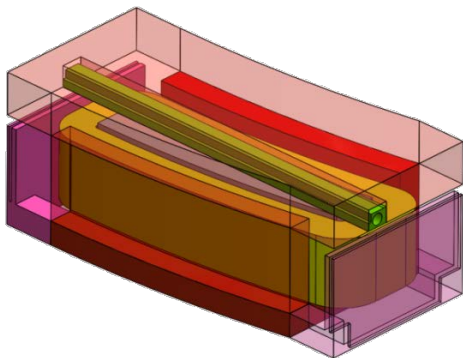
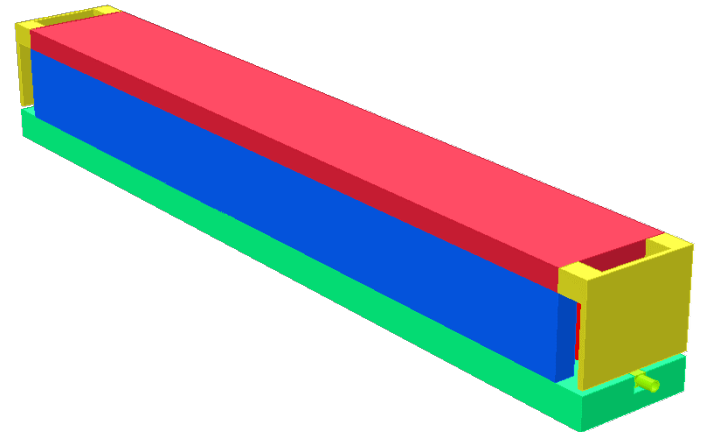
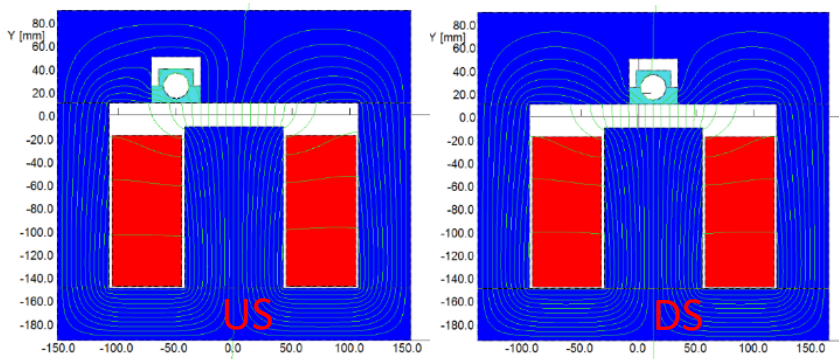



Slotted-pipe kicker design for DR

- Similar design was done in HEPS project(The HEPS Booster kicker)
- $E=1.1\text{GeV}$, Total kick angle: $\theta=1.5\text{mrad}$
- Kick strength= 0.024T , length of kicker= 0.25m , distance between two electrodes= 44mm , pulse width $<250\text{ns}$
- $U=d\phi/dt=0.024*0.044*0.25/(100*10^{-9})=2640\text{V}$.

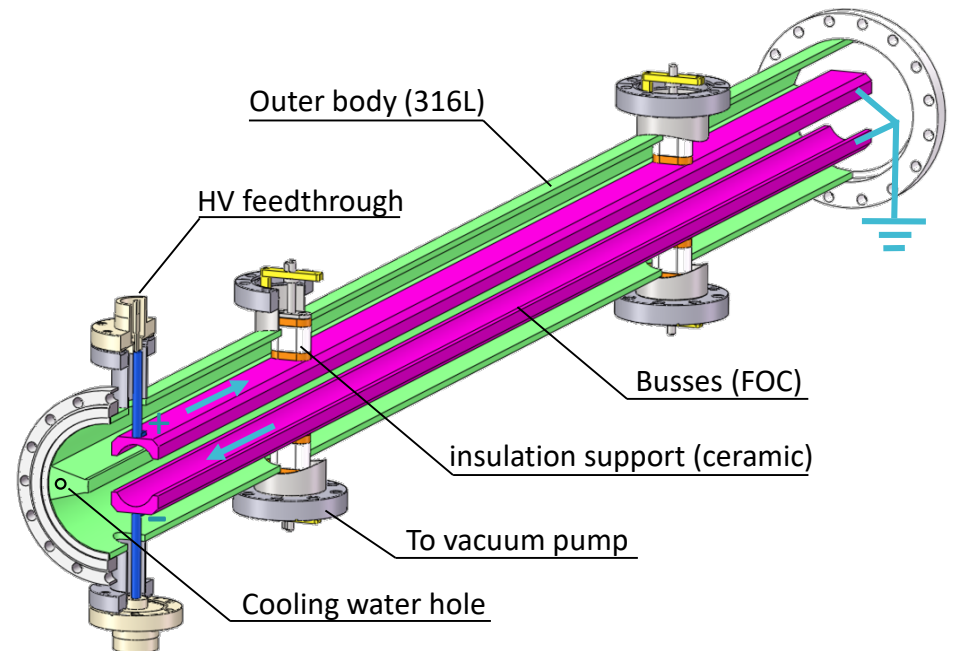
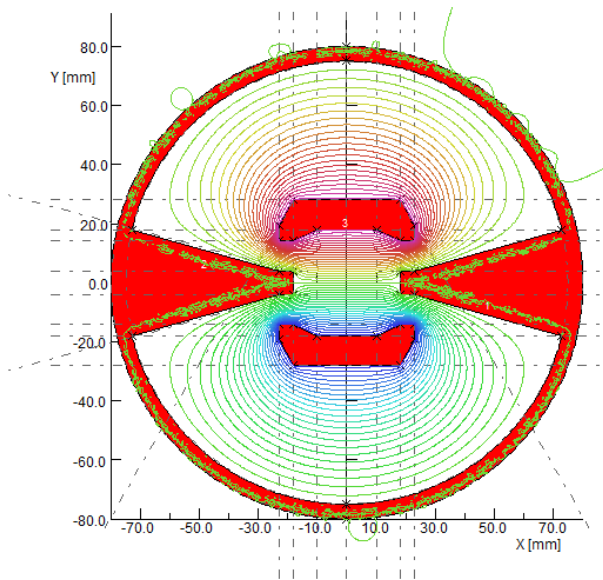
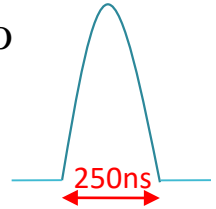



Strip-line kicker design for booster LE inj.

• Kick strength

- Total kick angle: $\theta=0.11\text{mrad}$
- $E=10\text{GeV}$, $d=55\text{mm}$, $g=1 \Rightarrow U \cdot L > 30.25\text{kV} \cdot \text{m}$
- Total strip-line kicker electrode length $L=1\text{m} \Rightarrow U > 30.25\text{kV}$ (or $\pm 16\text{kV}$)

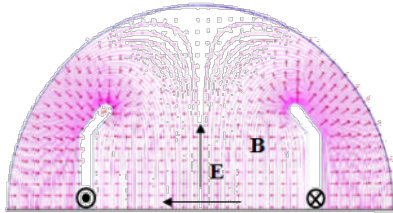
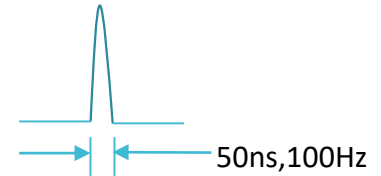

$$F_{E+B} = 2 \frac{Uq}{d} \quad \theta = \theta_E + \theta_B = 2\theta_E = 2g \frac{eU}{E} \frac{l}{d}$$

$$g = \tanh\left(\frac{\pi w}{2d}\right) \quad \tanh(x) = \frac{e^{2x} - 1}{e^{2x} + 1}$$

Here, θ is kick angle(rad); E is beam energy(eV); U is applied pulse voltage for both electrodes(V); l is strip-line length; d is the distance between the electrodes, g is the geometry factor, determined by the shape of the electrode. w is the strip-line width.

• Kick speed

- Min bunch spacing - $\tau=25\text{ns}$
 - ◆ Electrode length $l < 3.75\text{m} \Rightarrow l = 1\text{m}$
 - ◆ Electrical pulse Width $6.7\text{ns} < t_p < 43.3\text{ns} \Rightarrow$ Flat-top $t_{\text{top}} > 6.7\text{ns}$, Rise/fall Time $t_r/t_f < 18.3\text{ns}$

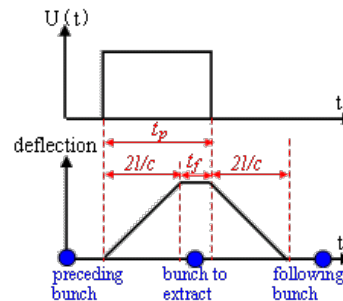
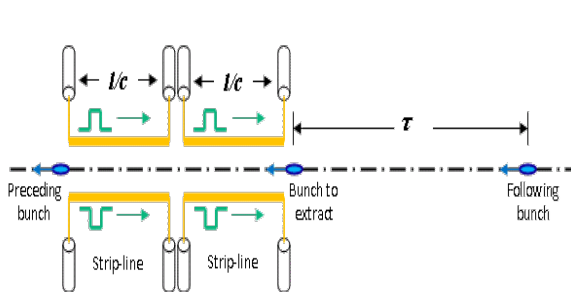

$$\begin{cases} l < c\tau / 2 \\ 2l/c < t_p < 2\tau - 2l/c \end{cases}$$



Strip-line kicker design for booster LE inj.

- Strip-line kicker and DSRD based short pulsed PS
- The similar hardware was developed in HEPS-TF progress.

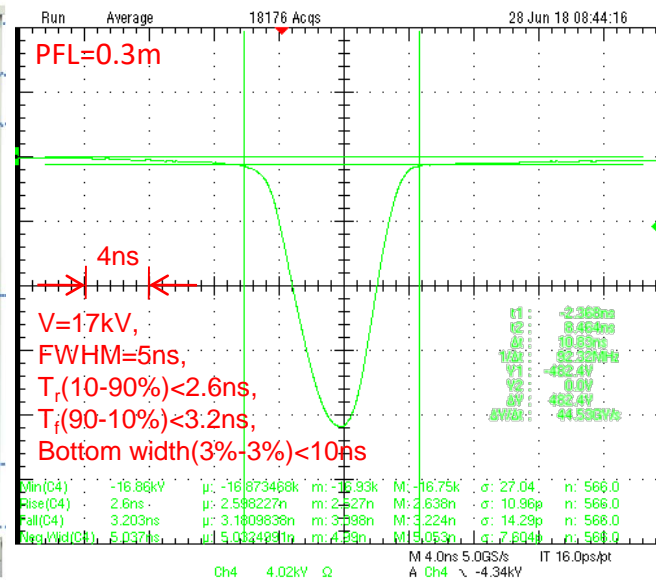
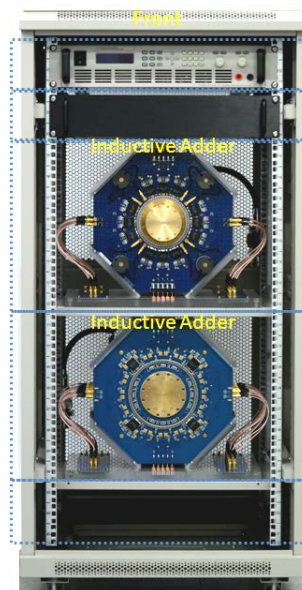
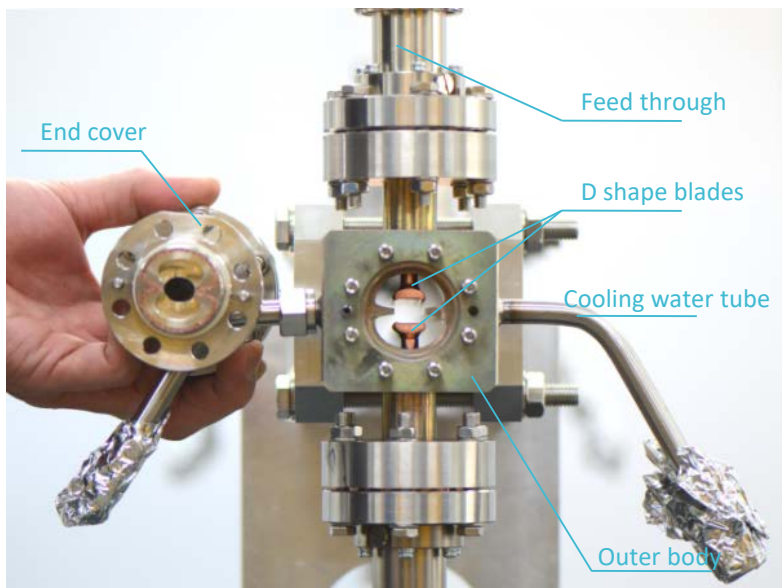
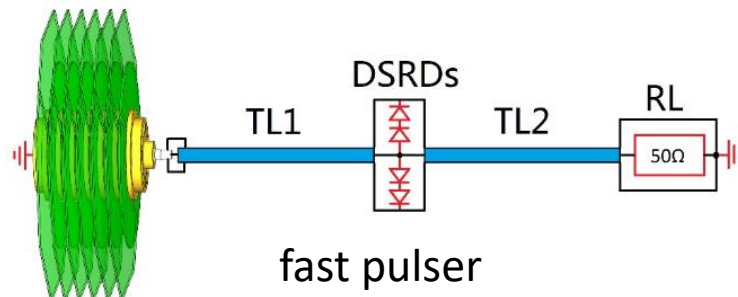
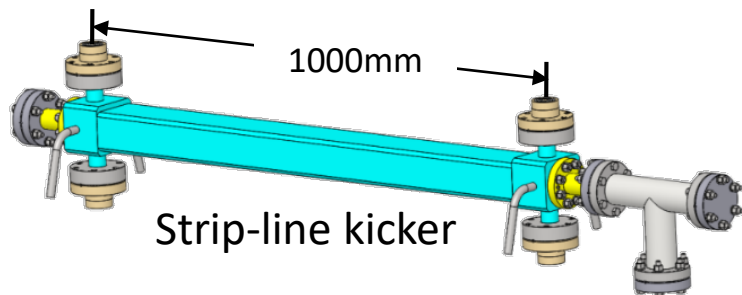



Distributed parameter (delay-line) dipole kicker

Features:

- Out-vacuum kicker with metallic coating ceramic vacuum chamber
- Solid-state adjustable pulse width PFN based Pulser
- The structure of delay-line kicker is complicated; the kind of kicker helps to achieve ideal trapezoid waveform.

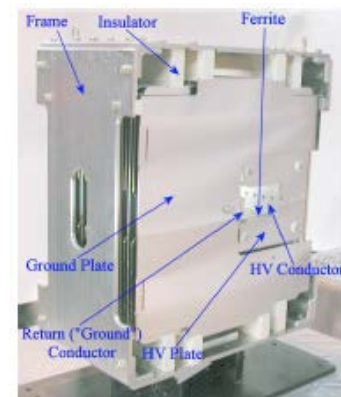
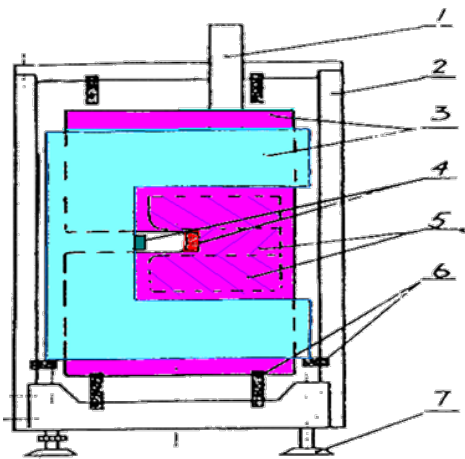
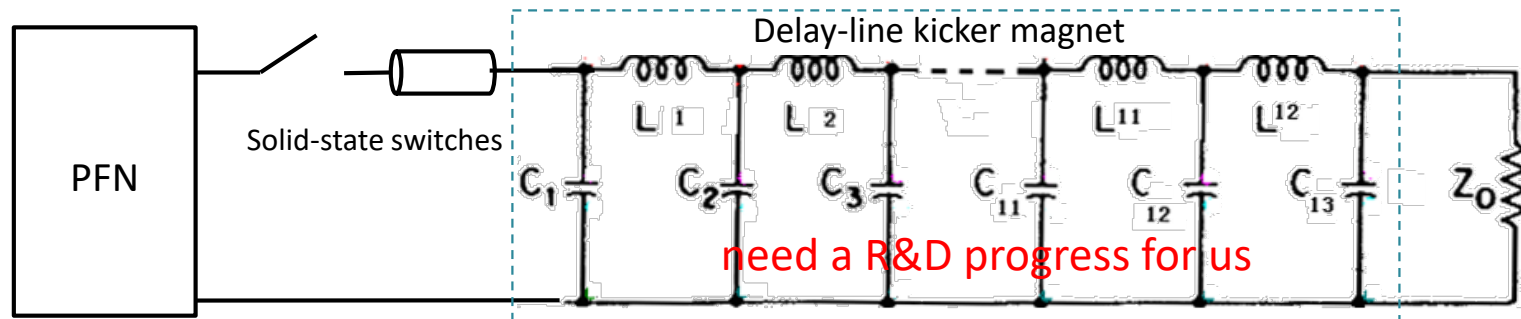
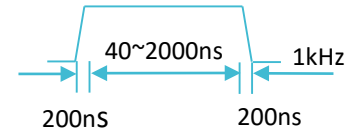



Lumped parameter dipole kicker magnet

Features:

- Out-vacuum **kicker** with metallic coating ceramic vacuum chamber
- Solid-state LC discharge half-sine Pulser
- It is easier than last type one.

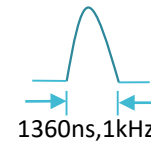
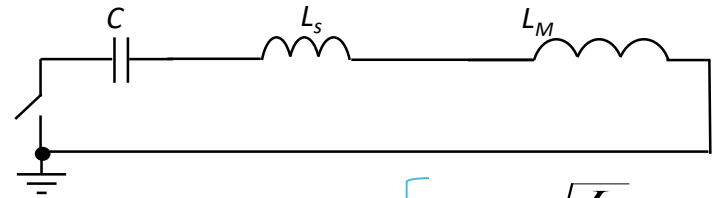
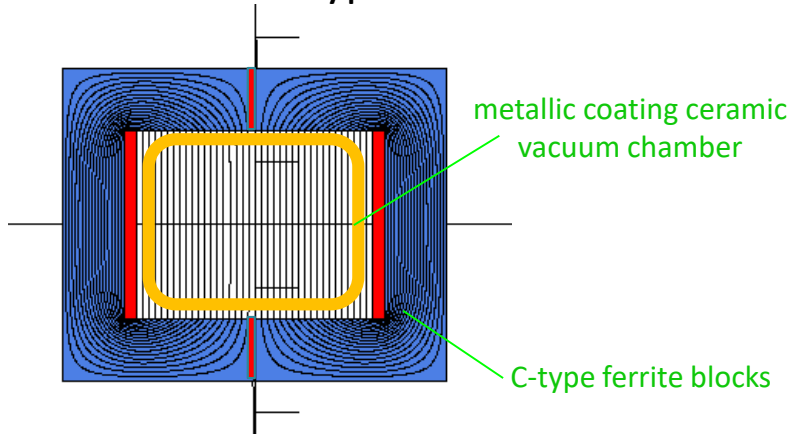

$$\left\{ \begin{aligned} Z &= \sqrt{\frac{L}{C}} \\ I &= \frac{U}{Z} \\ T &= 2\pi\sqrt{LC} \end{aligned} \right.$$

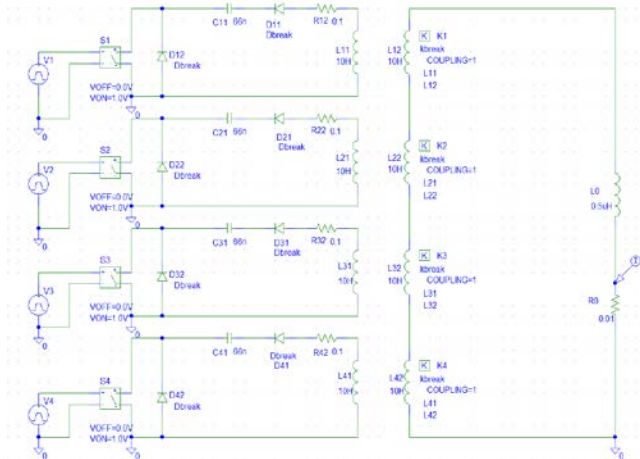

Inductive adder based on IGBTs

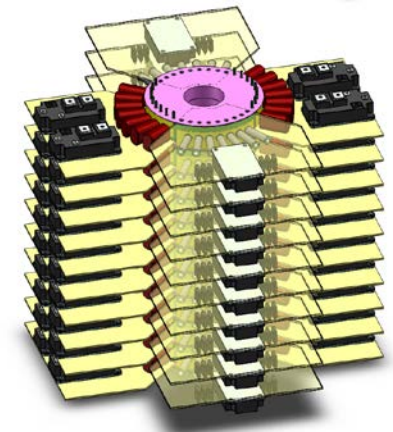
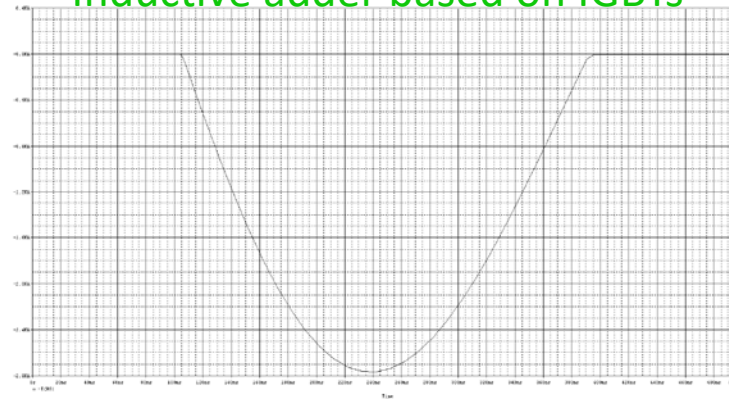



Why use nonlinear kicker injection?

The advantages of NLK injection:

- Off-axis injection, able to accumulate beam
- Less disturbance to the stored beam for TOP-UP injection
- Need smaller DA

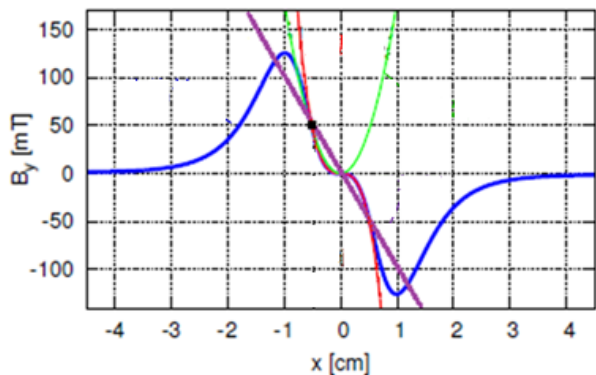

Pulsed Local Bump Injection

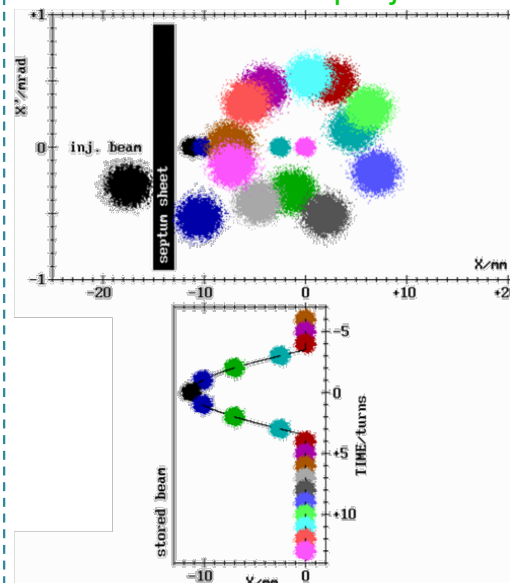

Nonlinear Kicker Injection

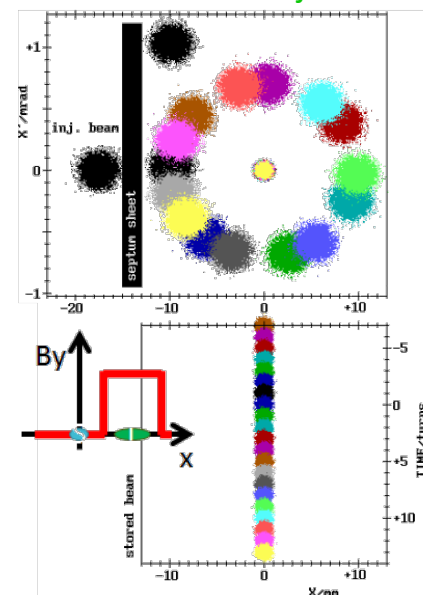

septum sheet

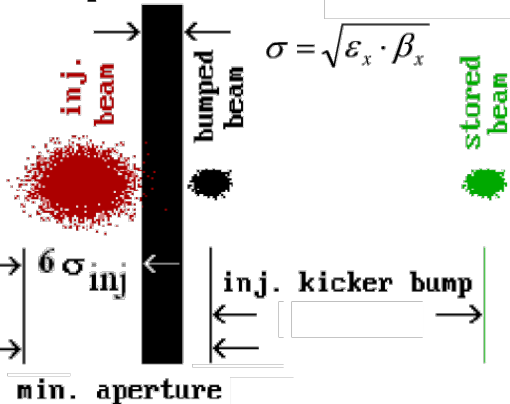

$$DA > [6\sigma_{storBeam} + 6\sigma_{injBeam} + S]^2 / \beta_x$$

septum sheet

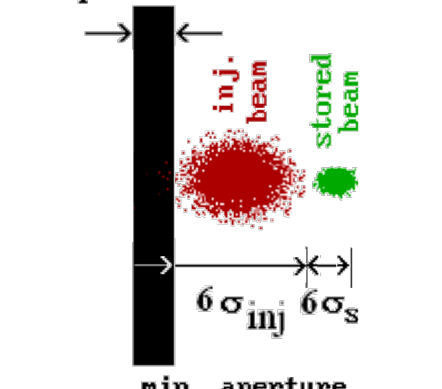

$$DA > [6\sigma_{storBeam} + 6\sigma_{injBeam}]^2 / \beta_x$$

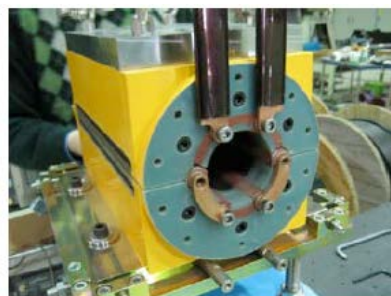

KEK Pulsed sextupole

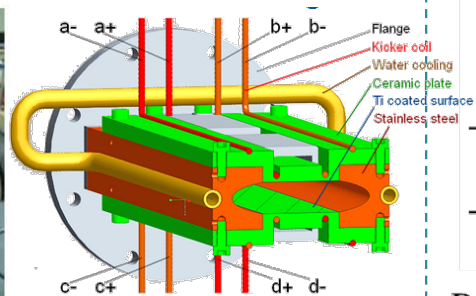

BESSYII NLK



Pulsed sextupole and NLK

- **Pulsed sextupole magnet:**

metallic coating ceramic vacuum chamber + Solid-state LC discharge half-sine Pulser .

- **Out-vacuum lumped parameter NLK:**

metallic coating ceramic vacuum chamber + Solid-state LC discharge half-sine Pulser

- **Out-vacuum distributed parameter NLK:**

metallic coating ceramic vacuum chamber + Solid-state adjustable pulse width PFN based Pulser

- It need to push the accelerator physics group to study if NLK is better choice for CEPC off-axis injection.

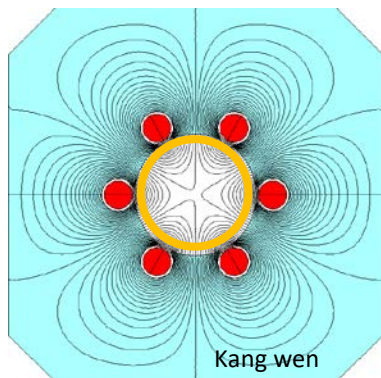
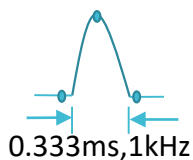

Pulsed sextupole magnet

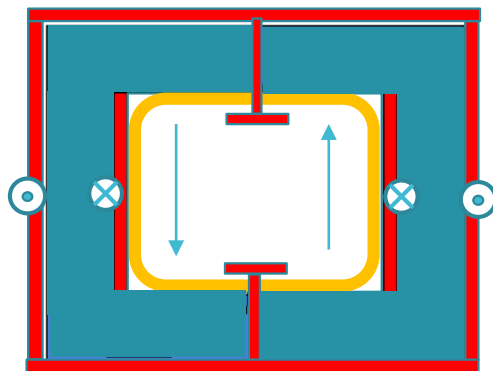

lumped parameter NLK

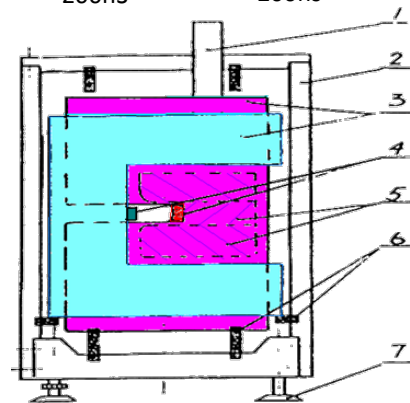

Distributed parameter dipole kicker

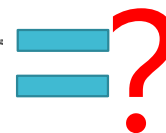

Distributed parameter NLK



Challenge of new beam separating system

1. Septa: horizontal out-vacuum DC Cu septum magnet (septum wall=10mm)
2. Dipole kicker and pulser: ? ?

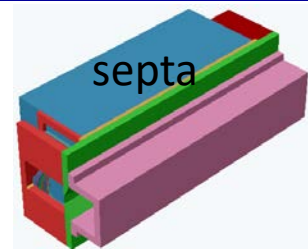

• Kicker pulser requirements are special:

- Flat-top dropping → compensate topology
- Amplitude long term stability → controlling technique
- High average power → Energy recycling
- High repetition rate

CW square wave

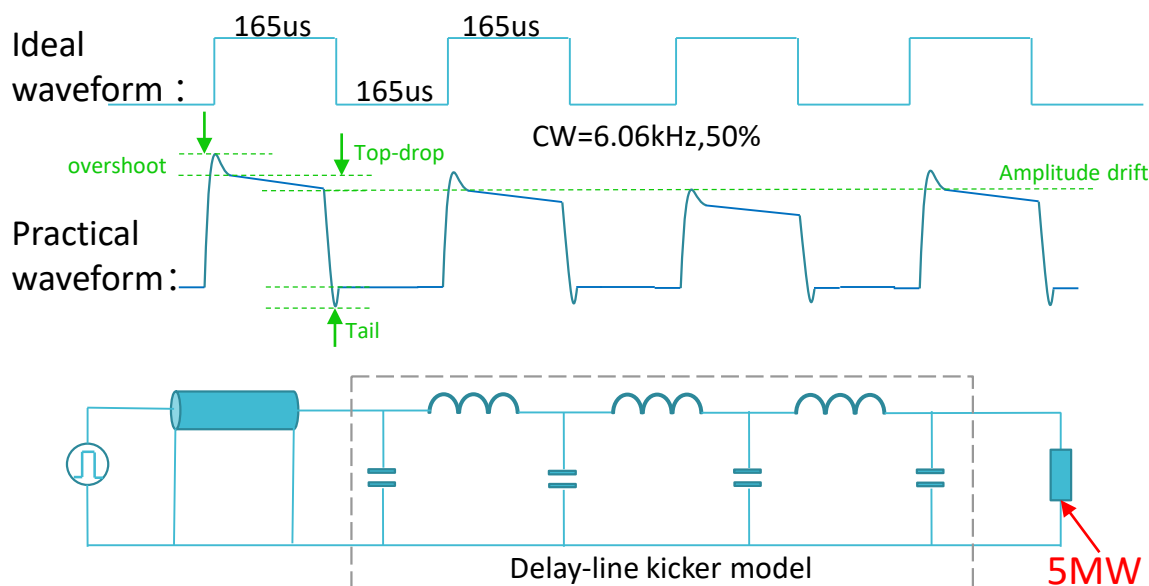

High repetition rate short wave

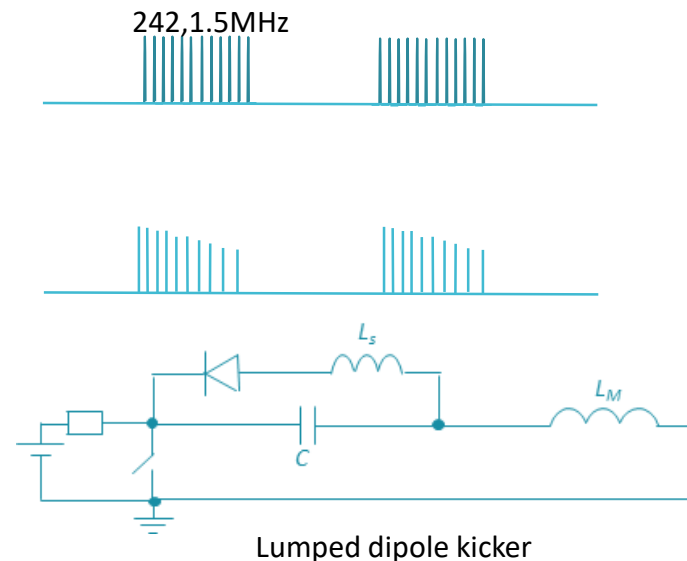



Hardware R&D Plan

Component	description	Number(set)	schedule
Vacuum chamber	Coated ceramic vacuum chamber	1	24 Mon.
Dipole kicker	Vacuum out distributed parameter dipole kicker magnet	1	24 Mon.
NLK	Vacuum out distributed parameter NLK magnet	1	12 Mon.
Trapezoid pluser	Solid-state pulse width adjustable trapezoid pluser	1	36 Mon.
CW pulser	continuous square wave pulser	1	36 Mon.

Year	2019	2020				2021				2022				2023			
Quarter	4 th	1 st	2 nd	3 rd	4 th	1 st	2 nd	3 rd	4 th	1 st	2 nd	3 rd	4 th	1 st	2 nd	3 rd	4 th
Vacuum chamber	█																
Dipole kicker		█	█	█	█	█	█	█	█	█							
NLK										█	█	█	█				
Trapezoid pluser				█	█	█	█	█	█	█	█	█	█	█	█		
CW pulser						█	█	█	█	█	█	█	█	█	█	█	█



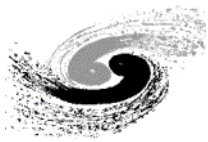

Summary

- There are 9 injection and extraction sub-systems in CEPC accelerator complex.
- Very preliminary injection layout design was done.
- We just figured out what kind of components needed in all sub-systems so far. We still need more input parameters for more detail design.
- Hardware R&D plan in the coming years was just proposed .

END

Thank you for attentions!!!

Backup slides