



中国科学院高能物理研究所
Institute of High Energy Physics
Chinese Academy of Sciences

CEPC Injector Damping Ring RF System Design and R&D

Dianjun Gong, Jiyuan Zhai, Dou Wang, Jie Gao

Institute of High Energy Physics, Chinese Academy of Sciences

20190122



THE HONG KONG
UNIVERSITY OF SCIENCE
AND TECHNOLOGY



HKUST JOCKEY CLUB
INSTITUTE FOR ADVANCED STUDY

IAS PROGRAM

High Energy Physics

January 7-25, 2019

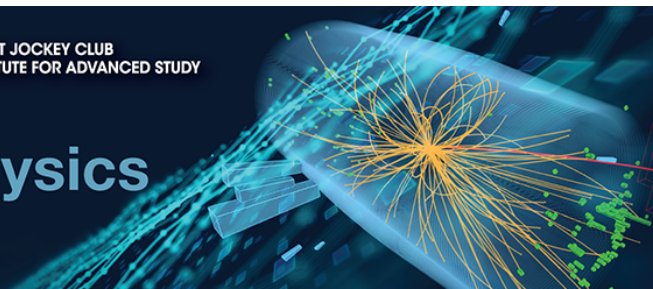

Outline

1 CEPC DR RF parameters

2 CEPC DR NC cavity

3 Cavity-beam interaction

4 Filling power of DR cavity

5 Conclusion

CEPC Damping Ring RF System

- For small emittance of position bunches and the update potential, the damping ring for positron linac is necessary for CEPC.
- The Damping Ring RF parameters are chosen to match the machine parameters and compensate the energy loss of bunches.
- Two 650 MHz 5-cell NC RF cavities are chosen.
- CEPC Damping Ring 650 MHz NC cavity is based on PETRA 5-cell 500 MHz cavity.
- The SR loss per turn is 36.3 keV. Because of low bunch charge and low beam current, the parasitic loss can be neglected compared with the SR loss.

CEPC Damping Ring main RF parameters

Circumference [m]	75.4
Beam energy [GeV]	1.1
SR loss/ turn [keV]	36.3
Revolution frequency [MHz]	3.98
SR power / beam [W]	433
Momentum compactor	7.82E-02
Beam current [mA]	11.9
Max Bunch charge [nC]	1.5
Number of bunches stored at a time	2
RF voltage [MV]	2.0
RF frequency [MHz]	650
Harmonic number	164
RF energy acceptance [%]	0.95
Acc. Phase [deg]	88.96
Syn. Tune	0.012
Synchrotron oscillation period [us]	21.7
Longitudinal damping time [ms]	7.6
Longitudinal quantum lifetime [s]	177
Beam storage time [ms]	20.0

Cavity Type	NCRF
Number of cell/ cavity	5
Cavity effective length [m]	1.15
Cavity number	2
Input coupler/ cavity	1
Total klystron number	2
Cavity voltage [MV]	1.0
Cavity Acc. Gradient [MV/m]	0.87
Q0	33600
R/Q [Ohm]	1100
Beam power/ cavity [W]	216
Wall loss/ cavity [kW]	27.0
Input power/ cavity [kW]	27.2
Coupling Coefficient	1.01
Optimal Q_L	3.34E+04
Cavity bandwidth at optimal Q_L [kHz]	19
Detuning angle [deg]	-12.4
Cavity filling time [us]	16.3
Optimal detuning at optimal Q_L [kHz]	-2.14
Cavity stored energy [J]	0.22

➤ 5-cell 500 MHz PETRA cavity

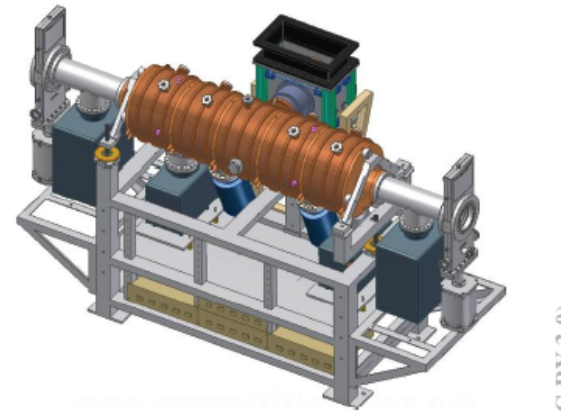
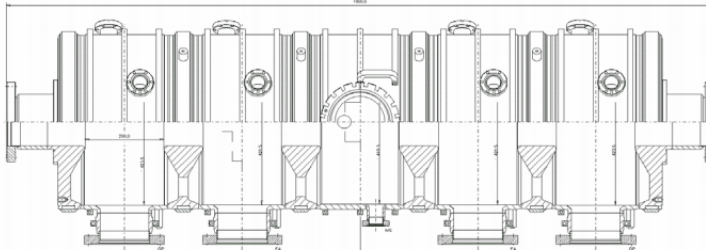

Figure 1: Layout of 5-cell Petra Cavity with All it's accessories.

Disc #: 1 2 3 4 5 6
 Cell #: 1 2 3 4 5 6



Flange neck diameters: 2x DN35, 1x DN125; 2x DN35, 1x DN125; 2x DN35, 1x DN144; 2x DN35, 1x DN125; 2x DN35, 1x DN125

Flange types: 2x DN35 CF, 1x DN150 CA; 2x DN35 CF, 1x DN150 CA; 2x DN35 CF, 1x DN150 SF; 2x DN35 CF, 1x DN150 CA; 2x DN35 CF, 1x DN150 CA

	Unit	Min.	Nom.	Max.	Remarks
Detuning due to temperature	kHz/°C		8,5		
Detuning due to plunger pos.	kHz/mm	10	20		Both plungers moved
Accelerating voltage	MV		1.09	1.73	
Accelerating gradient	MV/m		0.73	1.15	
Dissipated cavity power	kW		40	100	Tested up to 140 kW
Water flow rate (total)	m³/h		6		Sum of all discs & cells, optimised for maximum field flatness
Test pressure	bar		16		PN16
Pressure drop	bar			4	Cooling circuits in parallel and flow rates adjusted by orifice plates
Total length	mm		1800		(Flange to flange)
Cell length	mm		5*300		
Outside diameter	mm		445		Without water install.
Beam tube aperture	mm		120		
Weight	kg		504		Accessories and blind flanges excluded
Exhausting temperature	°C		150	180	

CEPC Damping Ring NC cavity

➤ Fundamental mode: TM010

Electric Field:

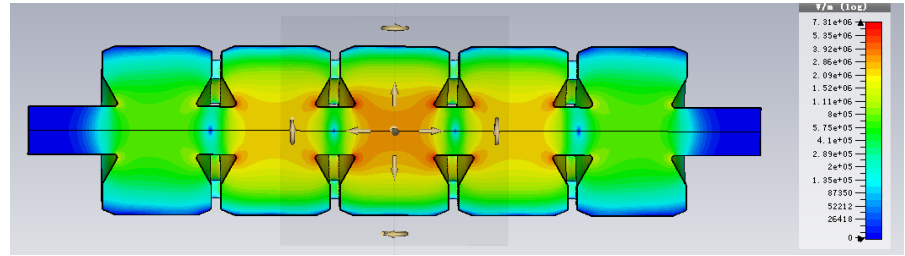
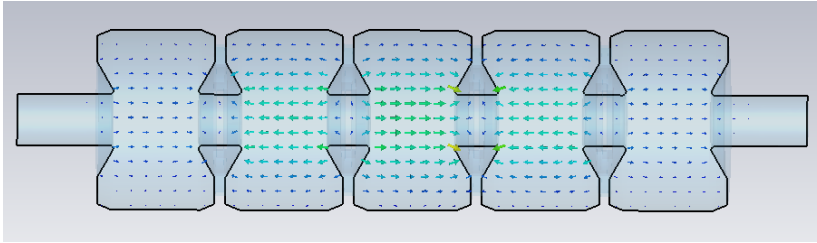

Magnetic Field:

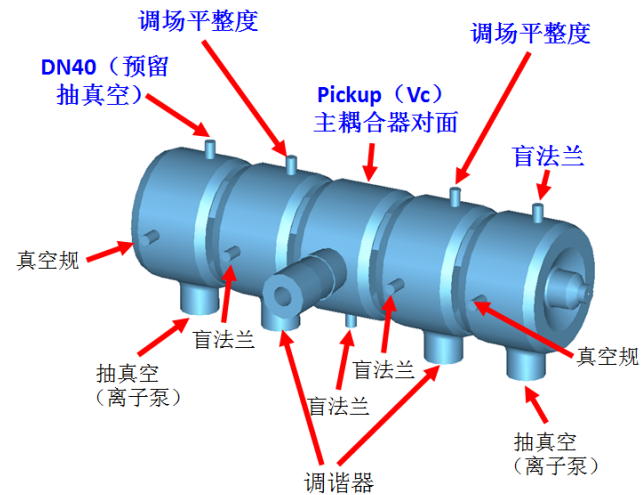
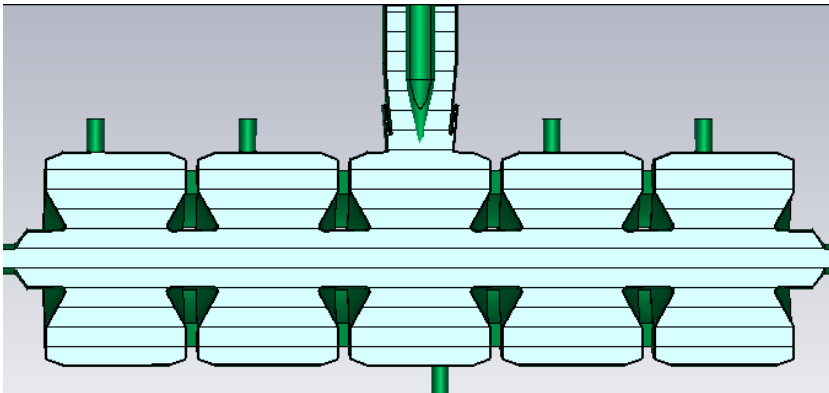
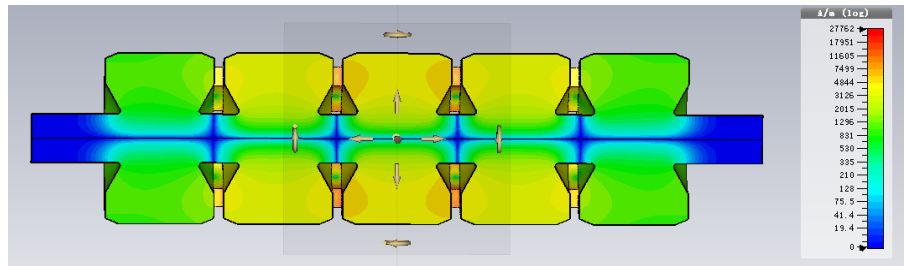
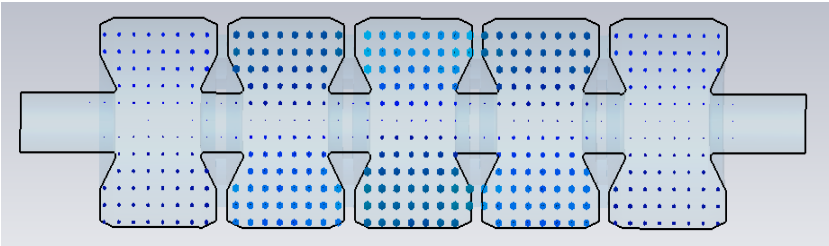

➤ Cavity HOMs

$$Z_{//}^{thresh.} = \frac{1}{N_{cav}} \cdot \frac{1}{f_{//,HOM}} \cdot \frac{2 \cdot E_0 \cdot v_s}{I_b \cdot \alpha_p \cdot \tau_z}$$

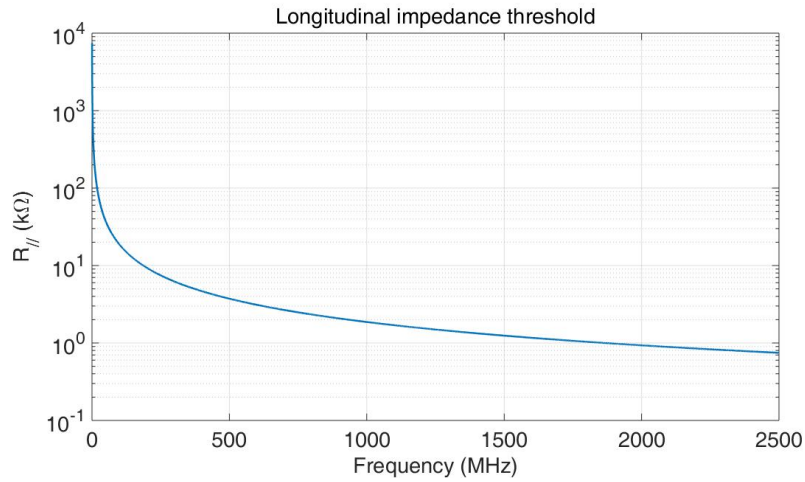

$$Z_{x,y}^{thresh.} = \frac{1}{N_{cav}} \cdot \frac{1}{f_{rev}} \cdot \frac{2 \cdot E_0}{I_b \cdot \beta_{x,y} \cdot \tau_{x,y}}$$

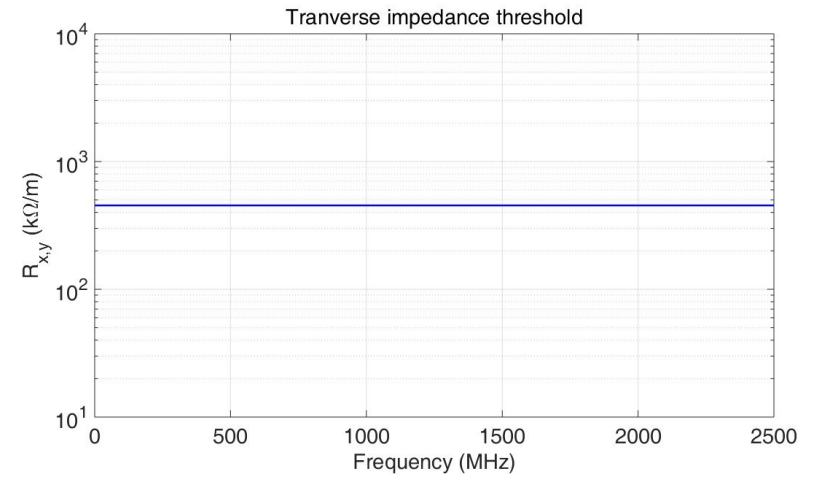

Mode	Frequency [MHz]	Qe	Rsh
TM011	934.478	28455	1971 [k Ω]
TM110	1059.605	41672	3458 [k Ω /m]
TM111	1272.243	33413	1002 [k Ω /m]
TM021	1671.819	47737	3932 [k Ω]

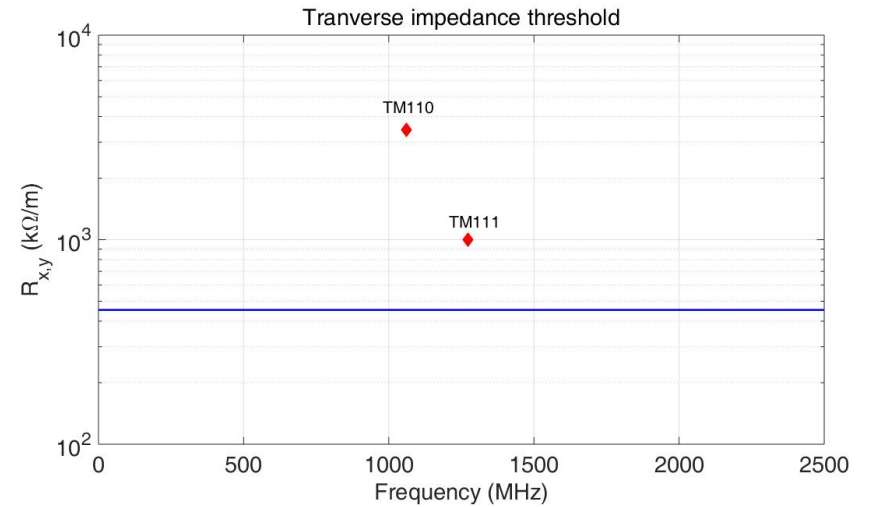
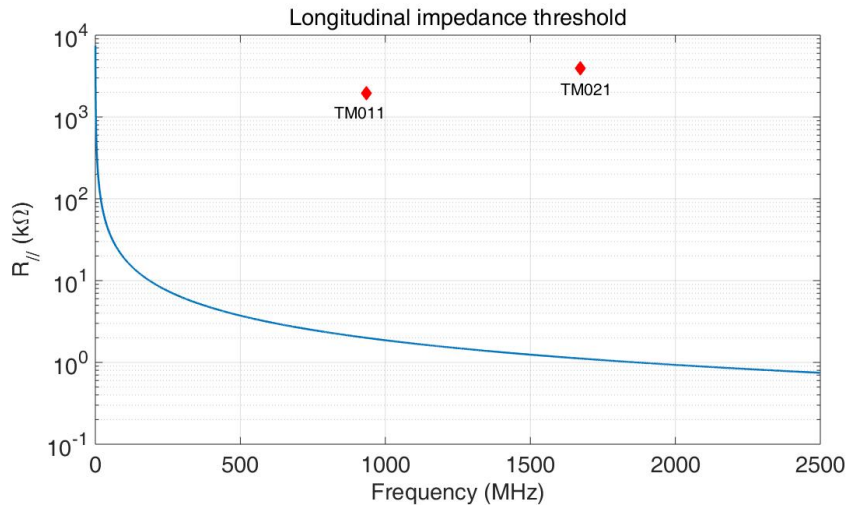

➤ HOM power loss

Mode	Frequency [MHz]	Qe	Rsh	P_{HOM} [kW]
TM011	934.478	28455	1971 [k Ω]	0.28
TM110	1059.605	41672	3458 [k Ω /m]	\
TM111	1272.243	33413	1002 [k Ω /m]	\
TM021	1671.819	47737	3932 [k Ω]	0.56

Time structure for CEPC DR

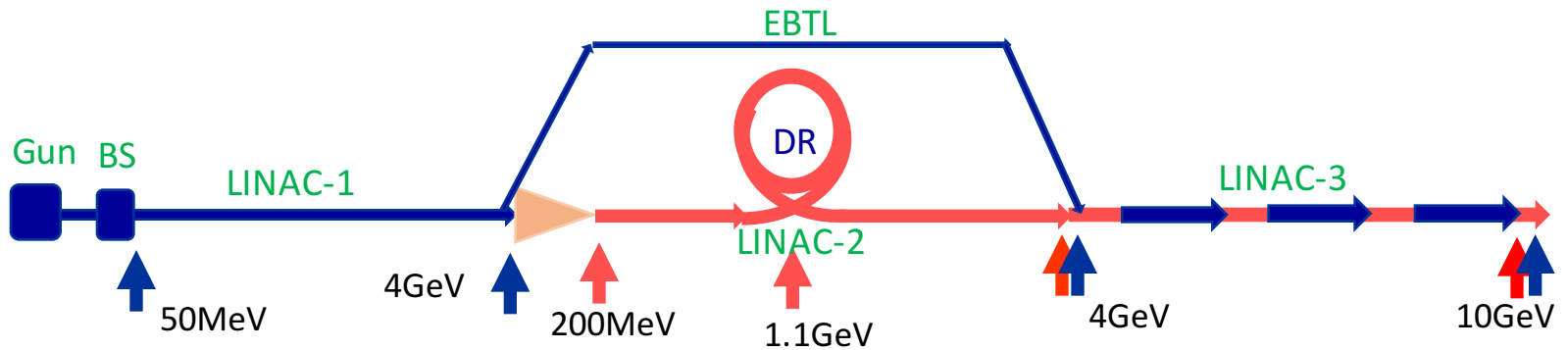

The injection beam structure:

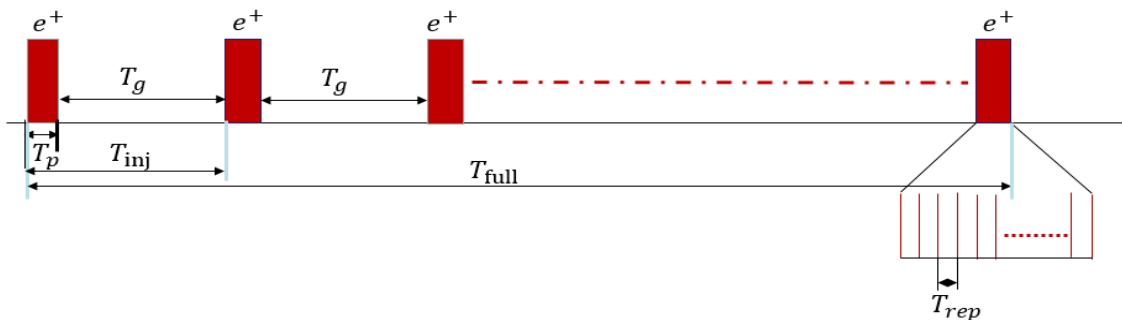

	Higgs	W	Z-pole
Pulse length T_p [s]	12.9	19.8	137.6
Gap length T_g [s]	34.1	111.2	300.4
Injection period T_{inj} [s]	47	131	438
Injection repetition T_{rep} [ms]	10	10	10
Full injection time [min]	10	15	132

➤ Transient beam loading for CEPC DR

Transient behavior of cavity voltage:

When the bunch pass the RF cavity, it extract the energy from the cavity, changing the amplitude and phase of cavity voltage.

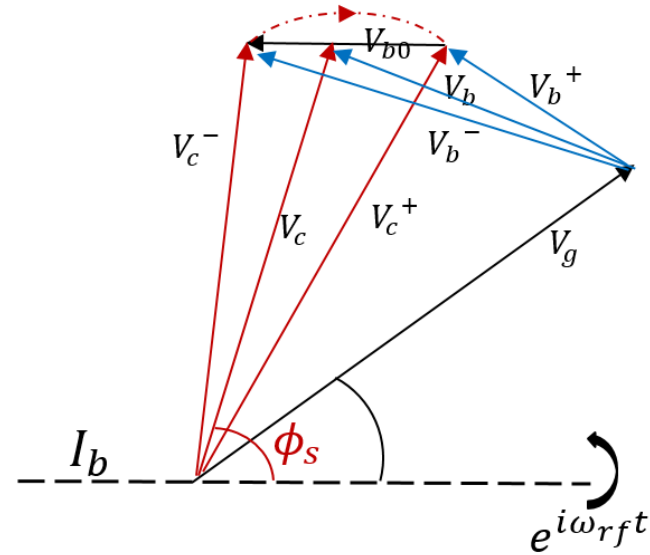

Time Variation of Cavity Voltage:

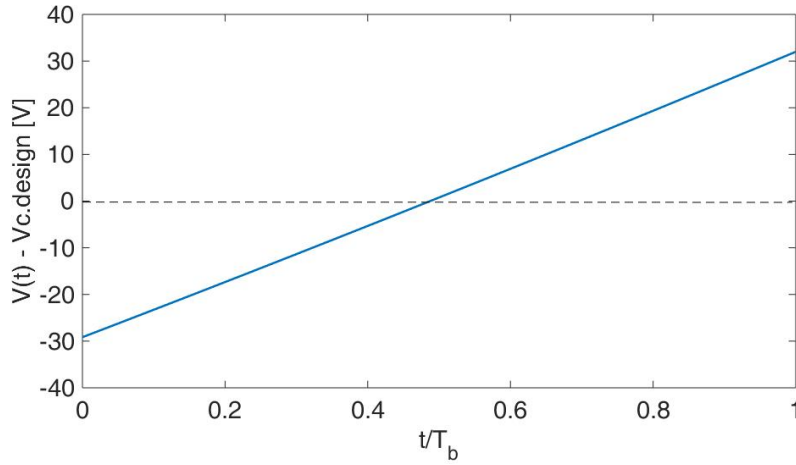

Time Variation of Cavity Phase:

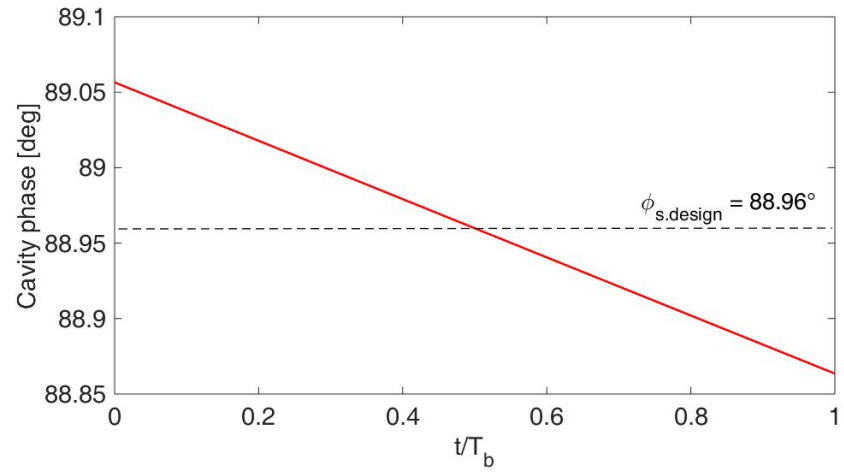

The beam can 'feel' half of the change, so both the amplitude and the phase of the effective acc. voltage are still the design values.

Time Variation of Cavity Stored Energy:

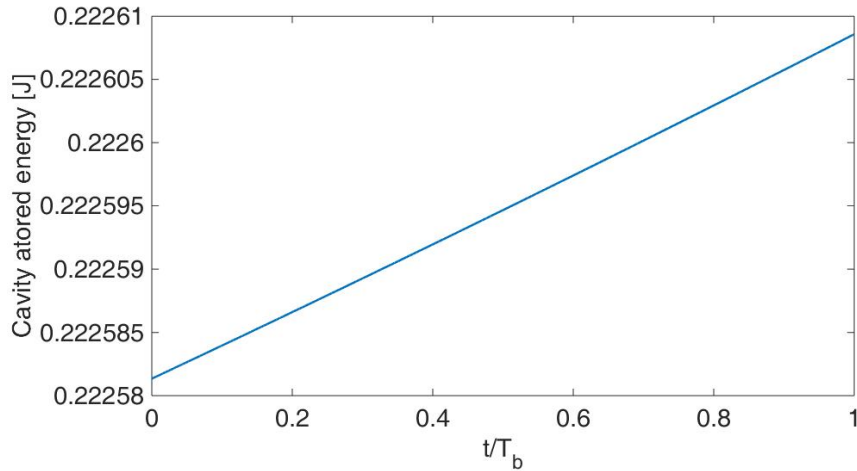

Time Variation of Reflected Power:

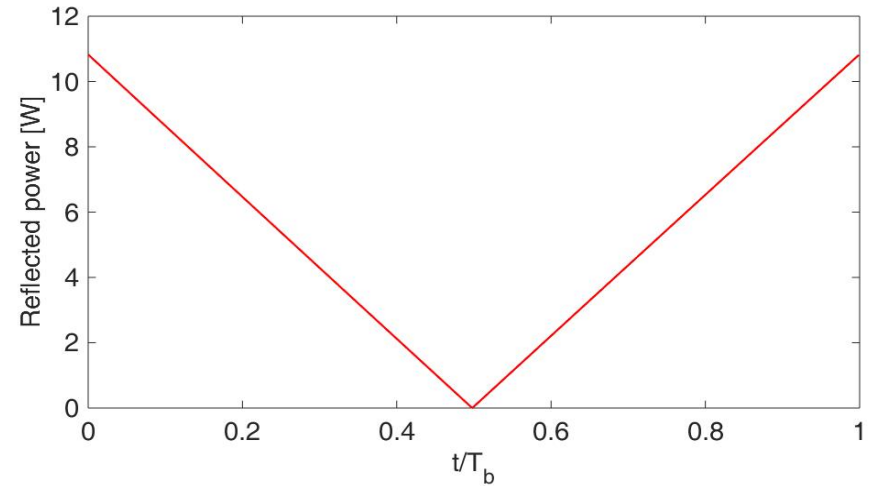

During one bunch spacing, the change of cavity stored energy is very little, that's because the cavity voltage change is only 0.06 %.

The reflected power also has a slight change.

In CEPC DR, the beam power is only 0.7 % of the cavity wall loss, so the transient beam loading effect of CEPC DR is very weak.

➤ Cavity voltage during the presence of beam:

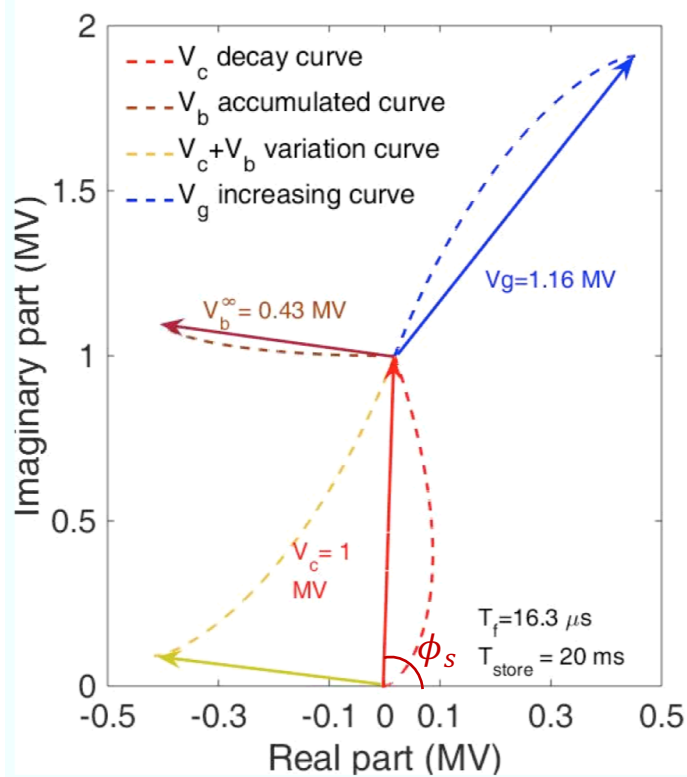

For optimum detuning:

$$P_g(\psi_m) = \frac{V_c^2}{R} \cdot \frac{(1 + \beta)^2}{4\beta} \left[1 + \frac{i_0 R \cos \phi}{V_c(1 + \beta)} \right]$$

$$\tan \psi_m = - \frac{i_0 R}{V_c(1 + \beta)} \sin \phi$$

For CEPC DR, $\psi_m = -12.4^\circ$, $P_{gb} = P_b + P_c = 27.2 \text{ kW}$

During the operation, the cavity voltage should be keep constant, both the amplitude and the phase. V_g compensate the time variation of the vector sum of V_c and V_b , the total voltage in the cavity remains constant.

➤ Detuning angle and operation current

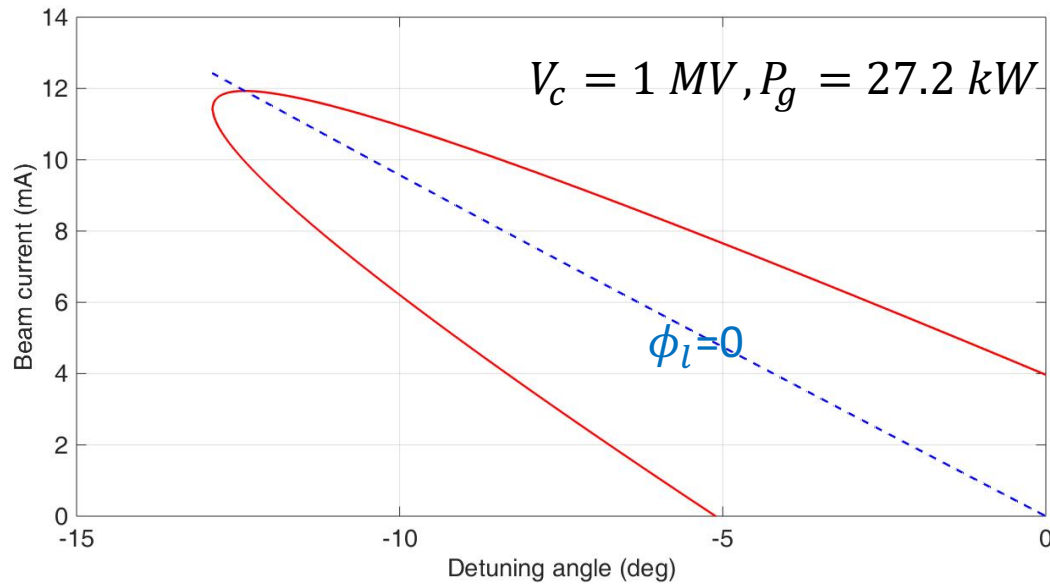

$$I_b = \frac{V_c}{R \cos \phi_z} \left[-\cos(\phi_z - \phi_b) \pm \sqrt{\cos^2(\phi_z - \phi_b) + \left(\frac{8R\beta_c P_g}{V_c^2(1 + \beta_c)} \right) \cos^2 \phi_z - 1} \right]$$

For optimum detuning, the maximum operation beam current can be got as the given input power.

Either P_g is increased or V_c is reduced, the RF system can operate outside the red curve.

➤ Cavity voltage during the absence of beam:

For CW operation

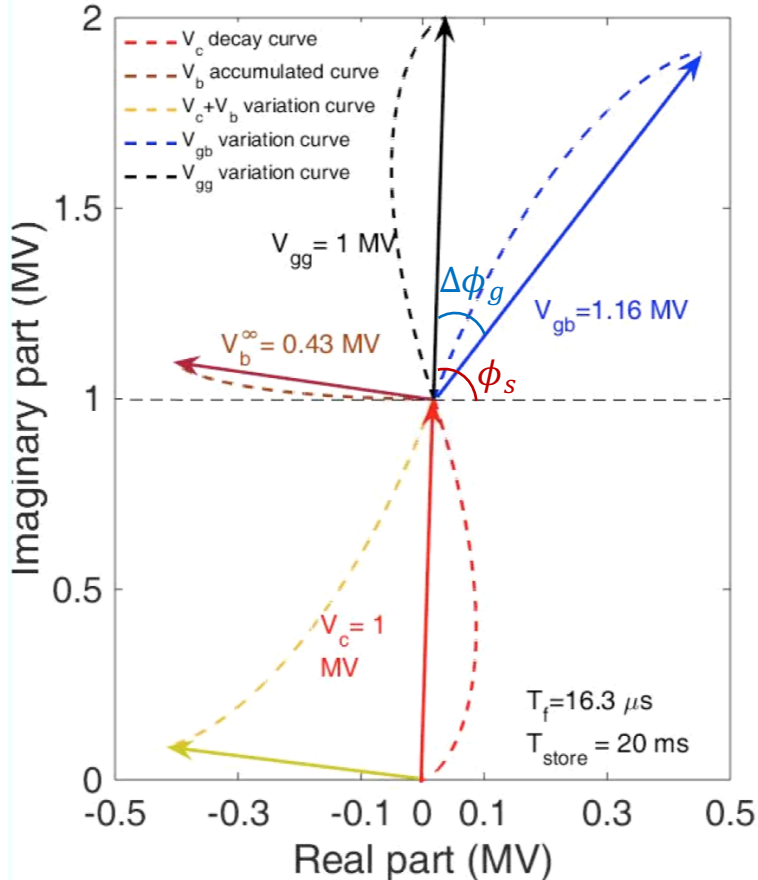

1. Phase jump

The phase jump for klystron is $\Delta\phi_g = -\psi_m = 12.4^\circ$.

2. Input power

When beam current is turn off, the power needed to compensate the cavity voltage decay:

$$P_{gg} = \frac{V_c^2 (\beta + 1)}{8R_L \beta \cos^2 \psi} = 28.4 \text{ kW}$$

3. Reflected power

The cavity is detuned, so the reflected power is not zero:

$$P_{ref} = \frac{[(\beta - 1)^2 + (\beta + 1)^2 \tan^2 \psi] P_g}{(\beta + 1)^2 \cos^2 \psi} = 1.4 \text{ kW}$$

The reflected power can also be written as:

$$P_{ref} = P_{gg} - P_c$$

4. Average power

The average power for a injection period (47 s):

$$P_{avg} = \frac{P_{gb} T_{pul} + P_{gg} T_{gap}}{T_{inj}}$$

Fundamental mode CBI for CEPC DR

CBI growth rate :

$$\tau_{\mu}^{-1} = \frac{I_b \alpha_c}{2v_s E_s} \cdot \sum_{p=0}^{\infty} \left[f_p^{\mu+} \operatorname{Re} Z_{\parallel} (f_p^{\mu+}) - f_p^{\mu-} \operatorname{Re} Z_{\parallel} (f_p^{\mu-}) \right]$$

$$f_p^{\mu+} = (pM + \mu) f_0 + f_s, \quad f_p^{\mu-} = [(p+1)M - \mu] f_0 - f_s$$

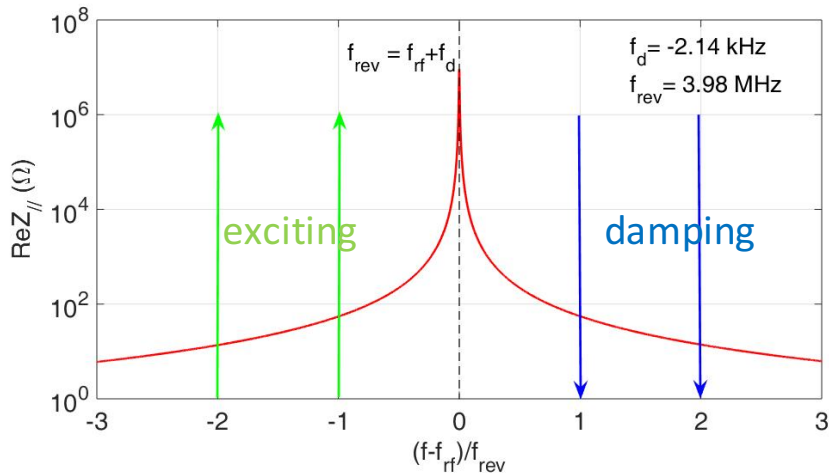

There are only 2 coupled-bunch modes in CEPC DR (-1 mode, -2 mode).

The cavity detuning $f_d \ll f_{rev}$, the cavity fundamental mode impedance is nearly symmetric to f_{rf} , so the CBI growth rate is much slower than Rad. Damping rate (131 Hz).

Filling power of CEPC DR cavity

The beam absence is quite a long time (34.1 s) for each injection period. It's better to turn off the generator power to save the input power and filling the cavity again before the next injection.

Fill the cavity to a desired voltage V_0 from 0 within a period of T_{fill} :

$$P_{fill} = \frac{V_0^2 (\omega_{1/2}^2 + \Delta\omega^2)}{4\omega_{1/2}^2 (1 - 2e^{-\alpha_{1/2}T_{fill}} \cos(\Delta\omega T_{fill}) + e^{-2\alpha_{1/2}T_{fill}}) \cdot 2R_L}$$

$\Delta\omega$ consists of pretuning, LFD and microphonics

P_{fill} is a function of filling time. For a shorter time, more filling power is needed.

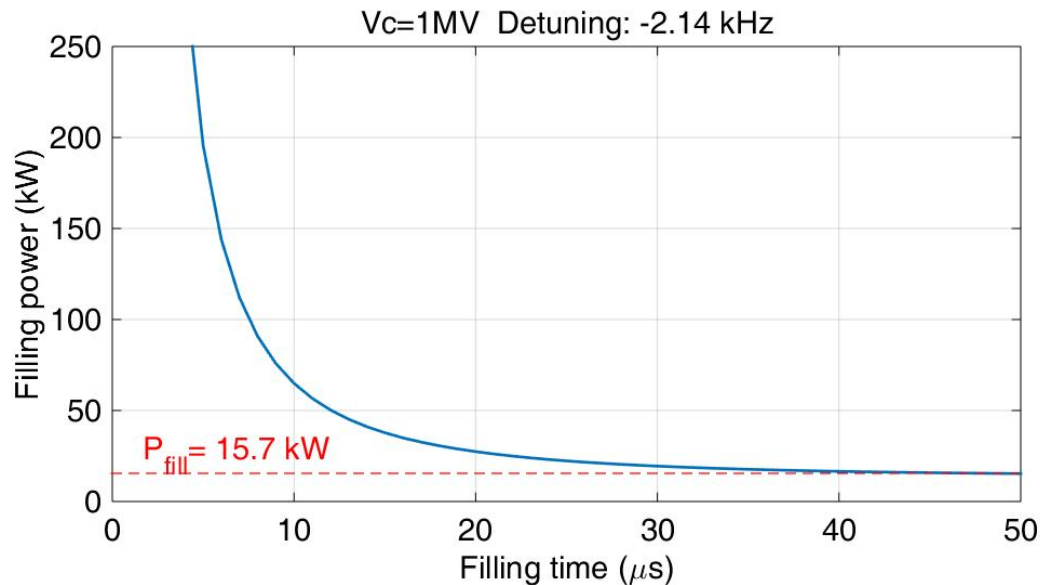

➤ Optimization for cavity filling power:

To perform resonance filling, the phase of the input power during the filling time should be precisely controlled:

$$\Delta\phi(t) = \int_0^t \Delta\omega(\tau) d\tau.$$

For CEPC DR, cavity 3dB bandwidth $f_{\frac{1}{2}} = 9.7 \text{ kHz}$, $f_{opt} = 2.1 \text{ kHz}$, so $f_{\frac{1}{2}}^2 \gg f_{opt}^2$, The cavity detuning's contribution to filling power is much smaller than the cavity bandwidth.

Filling time for different detuning:

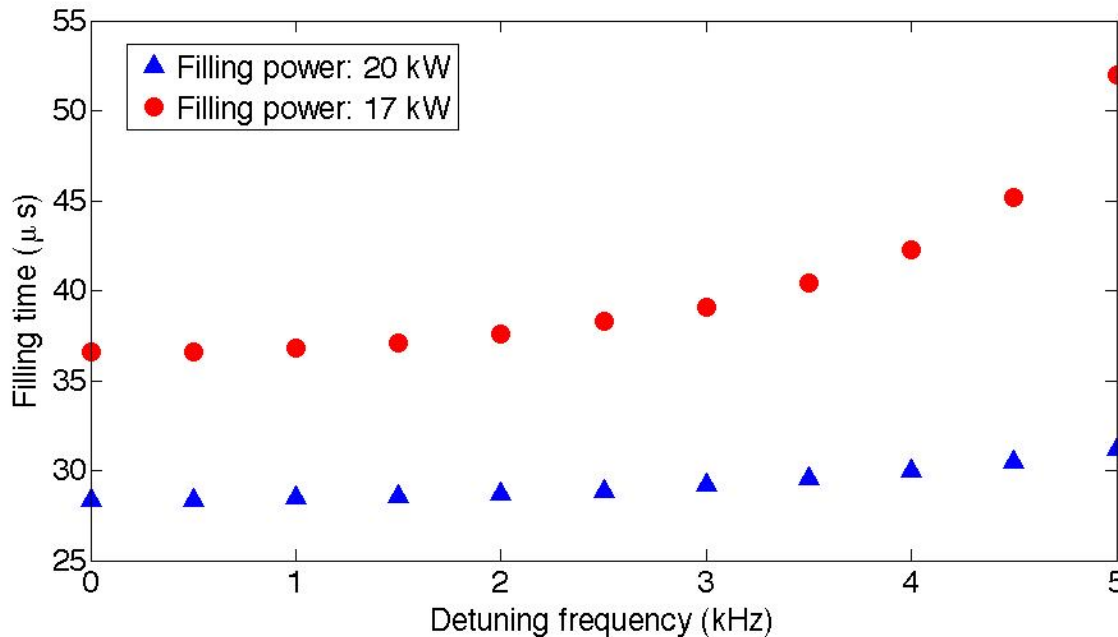

Conclusion

- The RF parameters for CEPC damping ring (DR) are given to match the machine parameters. Some key problems of the RF system are analyzed;
- NC cavity based on PETRA type is chosen for CEPC DR;
- Cavity HOM power is not a problem;
- During the gap time the RF source should be turned off and the filling power is about 15 kW.
- Both transient beam loading effect and coupled-bunch instability is very weak in CEPC DR.
- The study on the control loop of CEPC DR needs to be done.

Reference

Wang D, Chi Y, Gao J, et al. Design Study on CEPC Positron Damping Ring and Bunch Compressor[C]//8th Int. Particle Accelerator Conf.(IPAC'17), Copenhagen, Denmark, 14â 19 May, 2017. JACOW, Geneva, Switzerland, 2017: 1318-1321.

DATA SHEET 500MHz, 5-Cell Cavity, DESY-MHFe, January 2010.

Minty M G, Siemann R H. Klystron power specifications based on transient beam loading analysis in damping rings[C]. Particle Accelerator Conference, 1995., Proceedings of the 1995. IEEE, 1995, 5: 3217-3219.

P.B. Wilson. Transient beam loading in electron-positron storage rings. CERN-ISR-TH/78-23.

J. Y. Zhai, The RF parameters for CEPC PDR[R], internal report, 2016.

J. R. Zhang, CEPC injector linac R&D, CEPC International Workshop, Nov. 2018.

Thank you for your attention!